

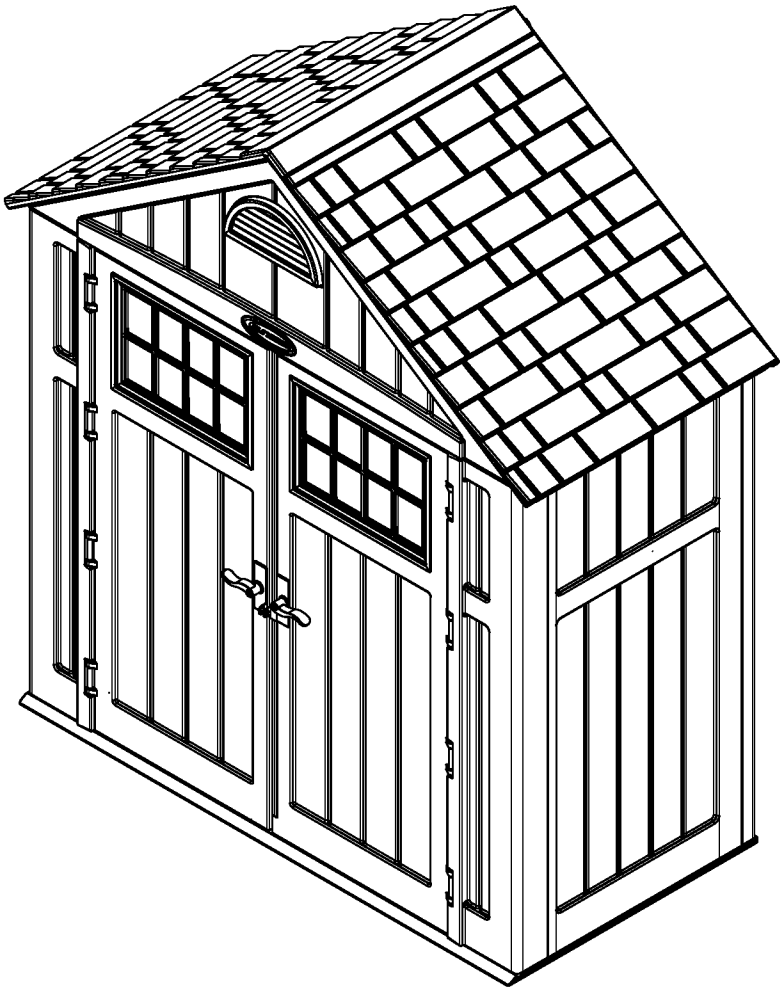



BMS7300 – Alpine™
Blow Molded Resin Storage Shed
ASSEMBLY INSTRUCTIONS



Quality Control Number:
Numéro de contrôle de qualité:
Número de control de calidad:

Assembled exterior dimensions 7' 6" W. x 3' 8" D. x 8' 7" H.

Before You Begin...

- **Consult your local authorities for any permits required to construct shed.**
Prior to the construction of your shed, check with the local building code official to review any required permits or building limitations.
- **A level and sturdy foundation is required before shed construction can begin.**
Site preparation information is available on pages 10-11. A foundation that differs from the suggestions within this manual could prevent proper assembly and may damage parts.
- **Read instructions thoroughly prior to assembly.**
This kit contains parts that can be damaged if assembled incorrectly or in the wrong sequence.
- **Please follow instructions.**
Suncast is not responsible for replacing parts lost or damaged due to incorrect assembly.
- **Check for all parts before you begin assembly.**
Using the provided parts check list on pages 5-9, verify that you have all the parts required to construct your shed model. **COMPLETE SITE PREPARATION AND FOUNDATION CONSTRUCTION BEFORE UNPACKING ALL PARTS.**
- **Assistance is required during entire assembly.** 



CAUTION

- Proper site preparation required.
- Shed not intended for use in extreme weather conditions.
- Shed not intended for storage of flammable or caustic chemicals.
- Store heavy items near the bottom of shed.
- Shed not intended for use by children.
- **DO NOT** stand, sit, or store items on storage shed roof.
- Treat carefully in extreme temperatures.
- Repair or replace broken parts immediately.
- Suncast is not responsible for damage caused by weather or misuse.
- At regular intervals inspect your shed to make sure that assembly integrity has been maintained.
- Periodically check that the location you have chosen to set your shed is still level.
- This kit contains parts with metal edges. Please be careful when handling.

Shed Safety and Care

- Hot items, such as recently used grills, blowtorches, etc., must not be stored in the shed.
- Heavy articles should not be leaned against the walls, as this may cause panel distortion and permanent damage.
- Keep roof clean of snow and leaves.
- The shed walls and roof sections have a textured exterior, much like vinyl home siding. Over time, dust may accumulate in the texture. When combined with moisture, this could encourage the growth of moss or mold on the shed. To maintain the look of your shed, we recommend cleaning it each year with mild soap and water. **DO NOT** use bleach, ammonia, or other caustic cleaners, and **DO NOT** use stiff bristle brushes. Failure to perform annual cleaning could result in permanent staining of the plastic. This is not a manufacturing defect and is not covered under warranty.

Tools Needed for Installation

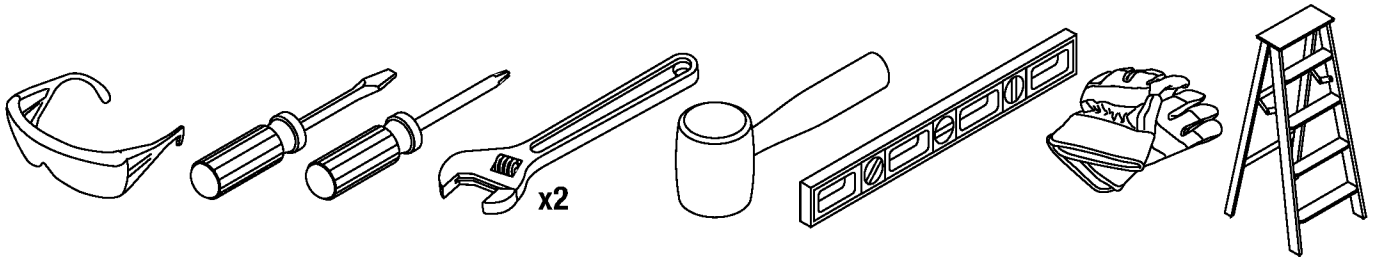

Assembly Day Tips

- Complete site preparation and foundation construction before unpacking parts and beginning assembly.
- **DO NOT** attempt to assemble on a day with strong winds.
- **DO NOT** attempt to assemble on days when temperature is below 32 degrees.
- Set aside appropriate amount of time to completely assemble shed.
- Make sure you have assistance nearby to lift and secure parts in place.
- Wear light duty work gloves while assembling shed.
- Once roof is assembled, a flashlight may be of use when assembling smaller components inside shed.
- Suncast provides extra hardware for small fasteners for customer convenience. In some cases, there will be extra small fasteners once the assembly is complete.

Note: This product contains parts that are used in different orientations to construct the shed. Please take note of the orientation of the parts shown throughout this instruction manual. Failure to follow instructions could result in damage to parts. Suncast is not responsible for replacing parts lost or damaged due to incorrect assembly.

Suncast Products and Replacement Parts

To purchase Suncast replacement parts and learn about other Suncast products, visit us online or call.



www.suncast.com
24 hours a day, 7 days a week, 365 days a year



1-800-846-2345 or 1-630-879-2050
Monday - Friday, 6 am - 8 pm CST

Parts - BMS7300 Walls and Floor

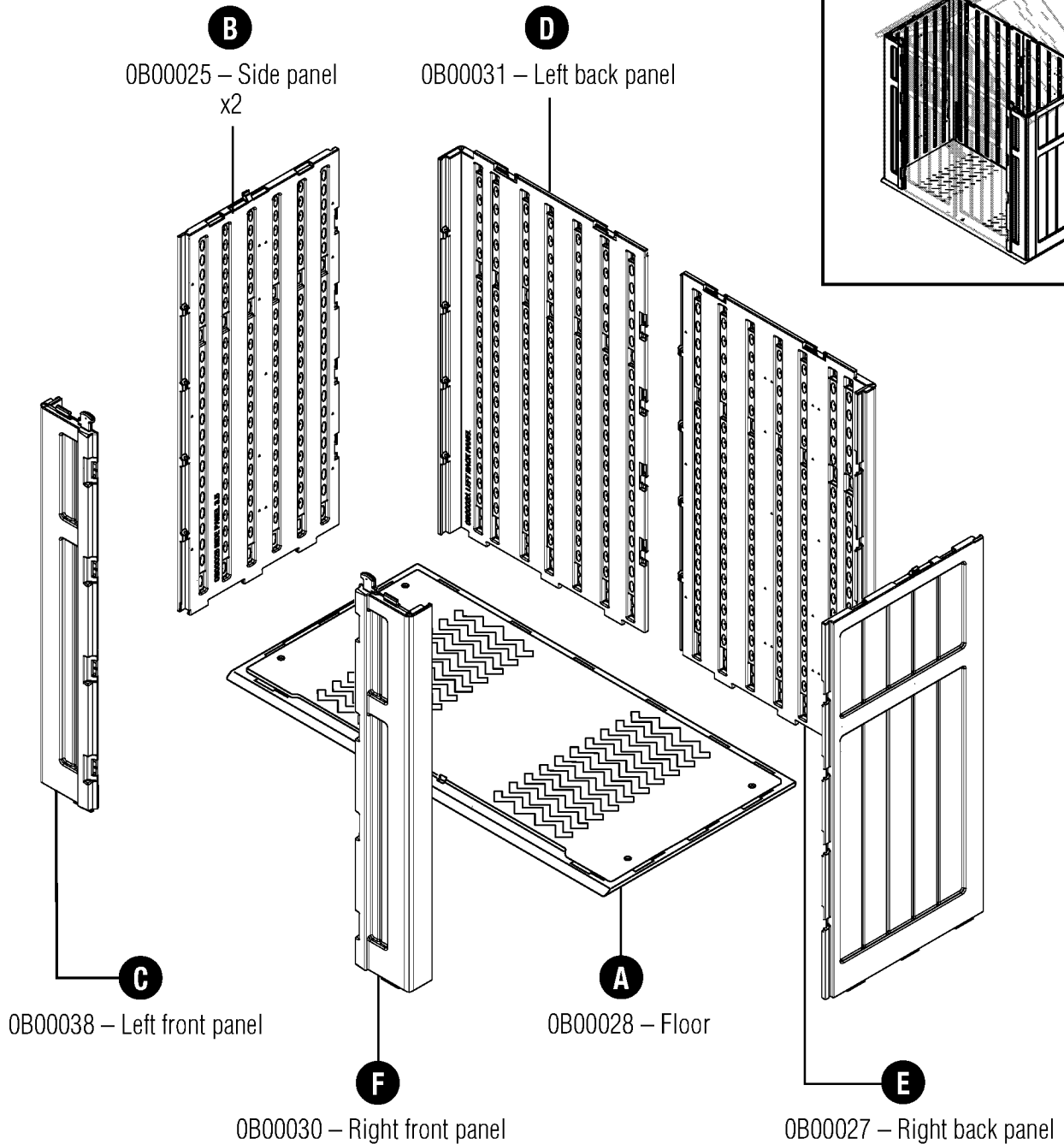

Parts - BMS7300 Doors

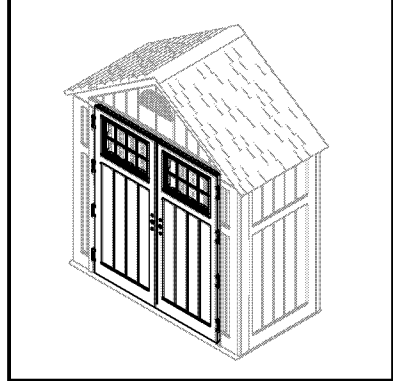

S

0440544B –
Door window
x1 set

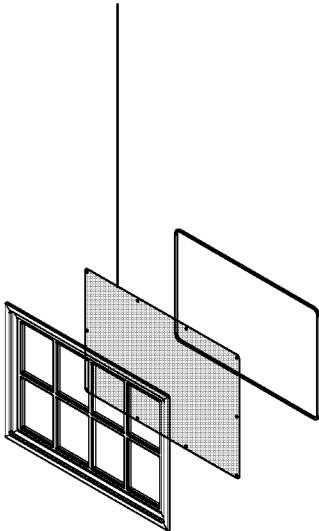

J

0B00041 –
Left door

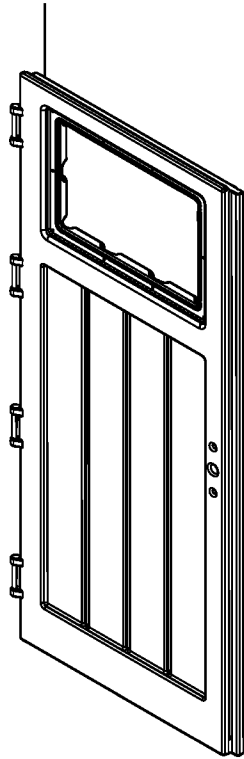

HH

0280384 –
D-ring bolt
x2

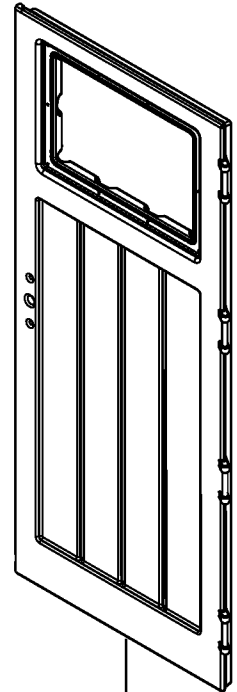
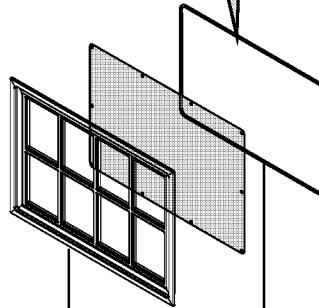
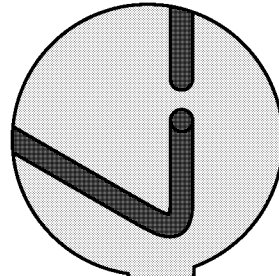

T

0102086 – Door
window frame
x2

I

0440546A – Door
window gasket
x2

K

0B00039 –
Right door

Parts - BMS7300 Headers and Roof

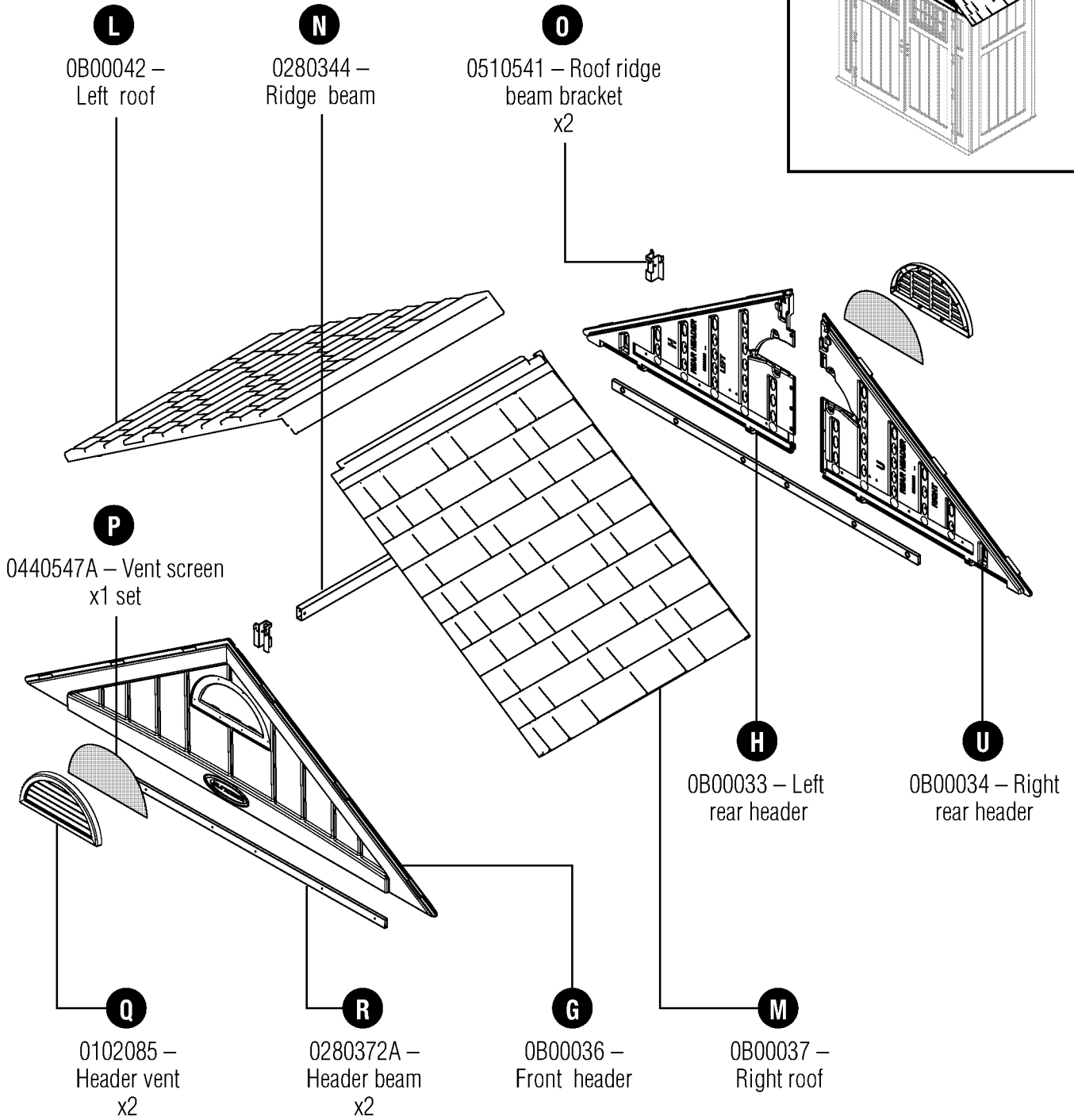
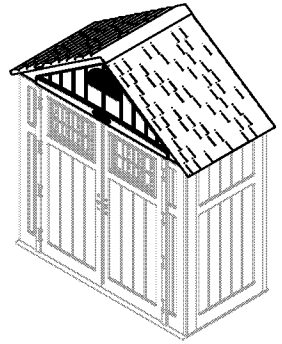

Hardware - BMS7300

0440661 – Hardware bag

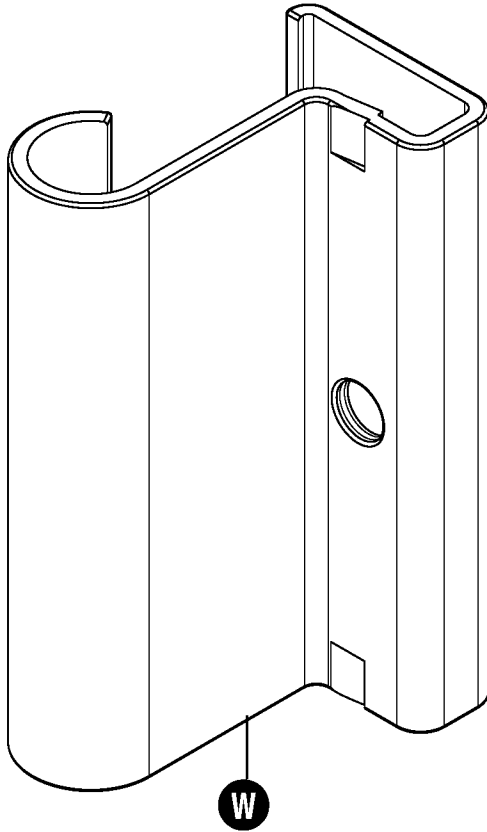

0510550A – Hinge plate
x8

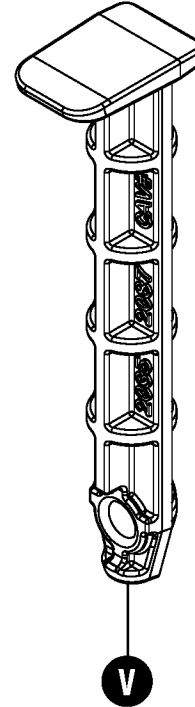

0102087 – Panel connector pin
x33

0480247A – Hardware bag

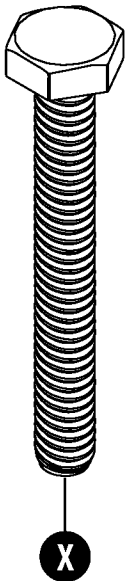

.25" x 2" Hex bolt
x4

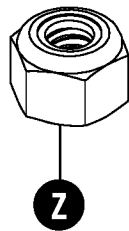

.25" Locking nut
x4

0480246B – Hardware bag

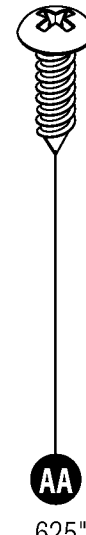

.625"
Pan head screw
x85

Hardware shown at actual size (*Unless otherwise noted.) Extra hardware provided. Not all are used.

Door Handle Kit - BMS7300

0440647A – Door Handle Kit

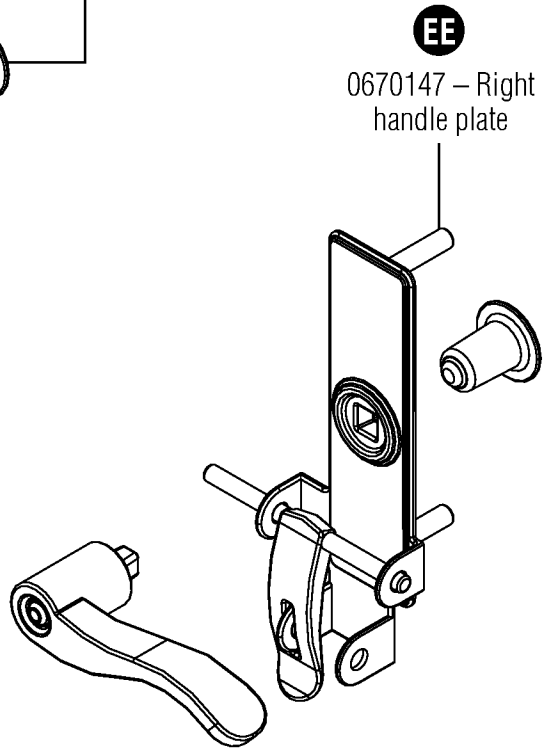
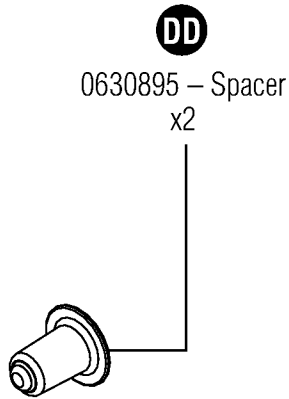
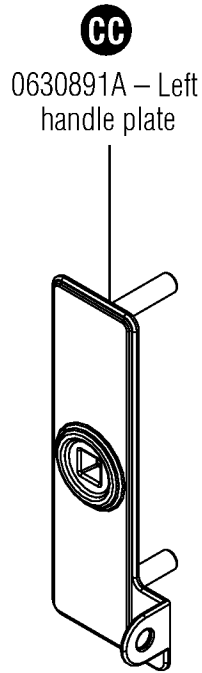
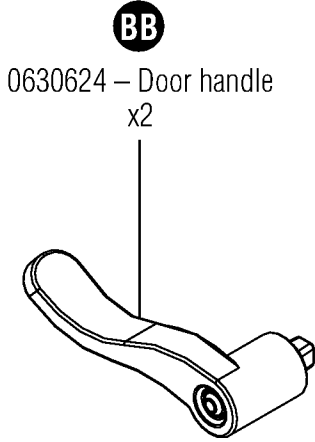
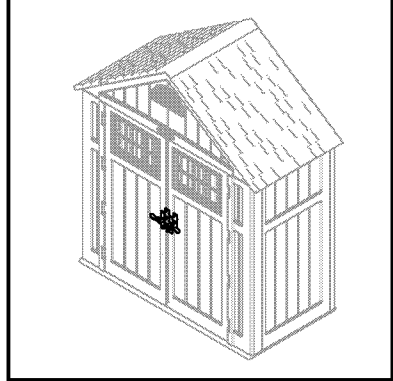

Hardware

0480309 – Hardware bag

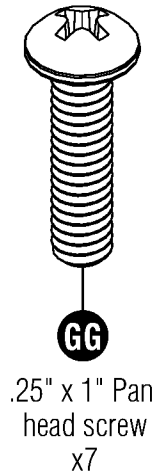
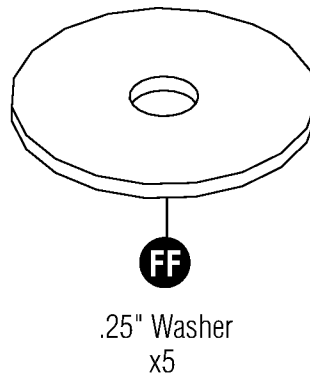
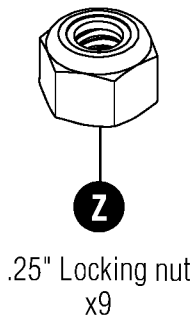
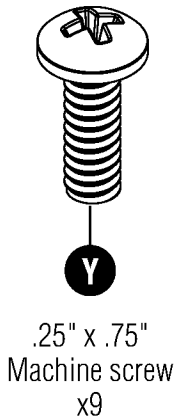

Hardware shown at actual size (*Unless otherwise noted.) Extra hardware provided. Not all are used.

Site Preparation and Platform Construction

Materials **NOT** supplied with BMS7300 Shed Kit

Note: Site preparation is required for this shed. Placing the shed on a constructed foundation is required. Without a constructed foundation, settling will occur, causing distortion and damage to the shed. Suncoast is not responsible for replacing parts damaged or property lost due to incorrect assembly.

Note: Complete the site preparation and foundation construction before unpacking parts and beginning assembly.

To prepare your shed site, follow the below steps:

- 1) Consult your local authorities for building codes and covenants before beginning foundation or erecting shed.
- 2) Before any digging, check with local utilities to determine location of buried cables, pipes, etc.
- 3) Decide which type of foundation you want:
 - Concrete slab, 4" thick

OR

- Wood platform

Use exterior grade wood. The wood platform should be set on pier blocks or footing. Consult your local retailer for help to determine the best anchoring method for your particular installation. The provided plans are sized for the minimum number of cuts to lumber and plywood.

4) Prepare the building site:

- The ground should slope away from the foundation area to provide drainage.
- The foundation surface must be flat and level.
- A vapor barrier should be provided to prevent excessive condensation in the shed.
- Follow local building codes for a proper vapor barrier.

5) Anchoring the shed to the foundation:

- Consult your local retailer for help to determine the best anchoring method for your particular installation.
- To secure the shed to a concrete slab, use masonry fasteners available at your local hardware retailer.
- To secure the shed to a wood platform, use 1/4" x 2" long lag screws with washers.

Anchoring floor panel to concrete slab

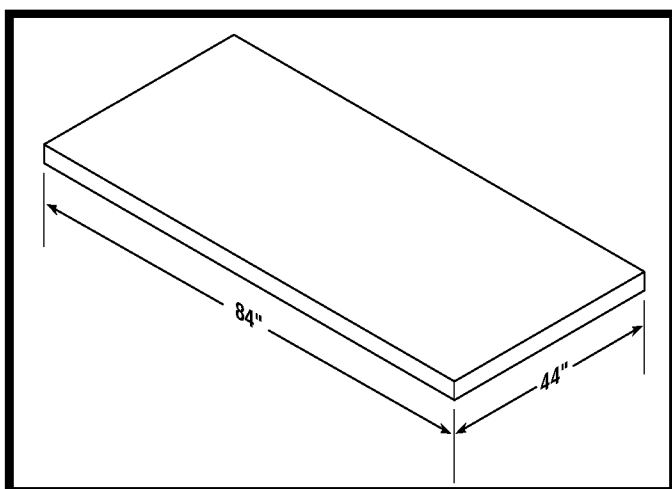

- Secure shed to concrete slab using masonry fasteners.
- Dimensions allow for shed to fit within the nearest 1" on each side.

Anchoring floor panel to wood platform

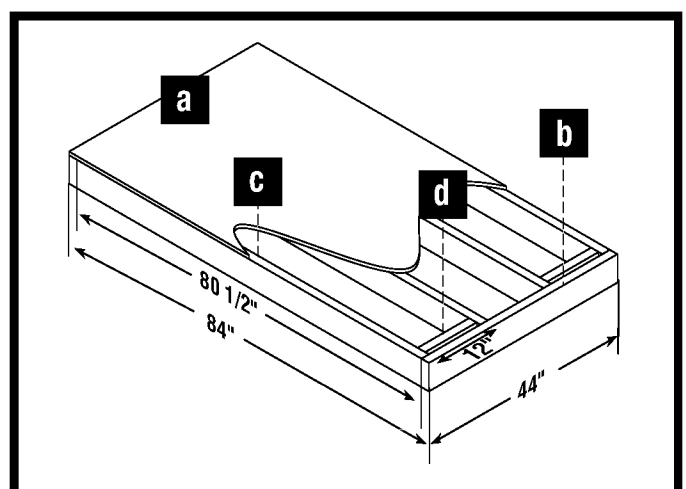

- Secure shed to wood platform using 1/4" x 2" lag screws.

Site Preparation and Platform Construction (continued)

Materials NOT supplied with BMS7300 Shed Kit

Wood platform critical spacing

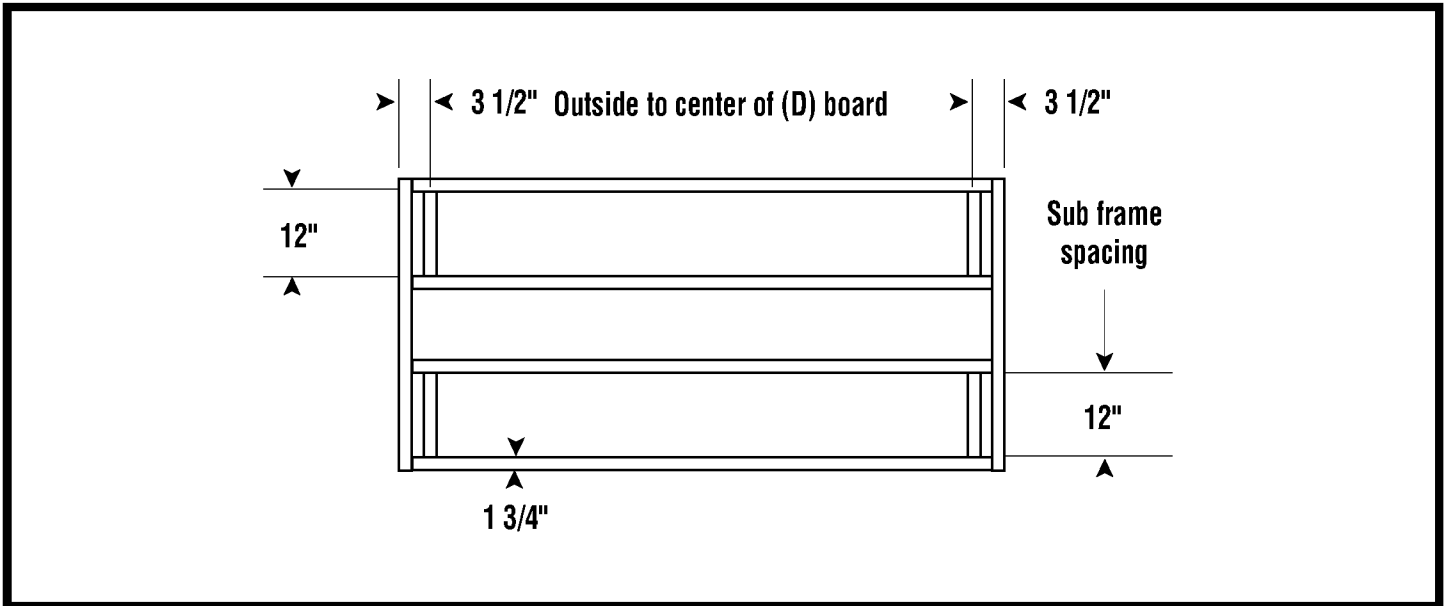

- Check all critical spacing measurements.

3D perspective diagram of the wood platform with labeled parts a, b, c, and d. Dimensions shown include: 80 1/2" for the length of the top board (a); 84" for the length of the side boards (c); 12" for the thickness of the side boards (c); 44" for the width of the platform; and 4" for the thickness of the bottom board (d).

Materials list

Item	Qty	Size
a	1	84" x 44" x 3/4"
b	2	2" x 6" x 44"
c	4	2" x 6" x 80 1/2"
d	4	2" x 6" x 12"

Door Pre-Assembly

Parts/hardware needed for door pre-assembly are shown on pages 6 and 8.

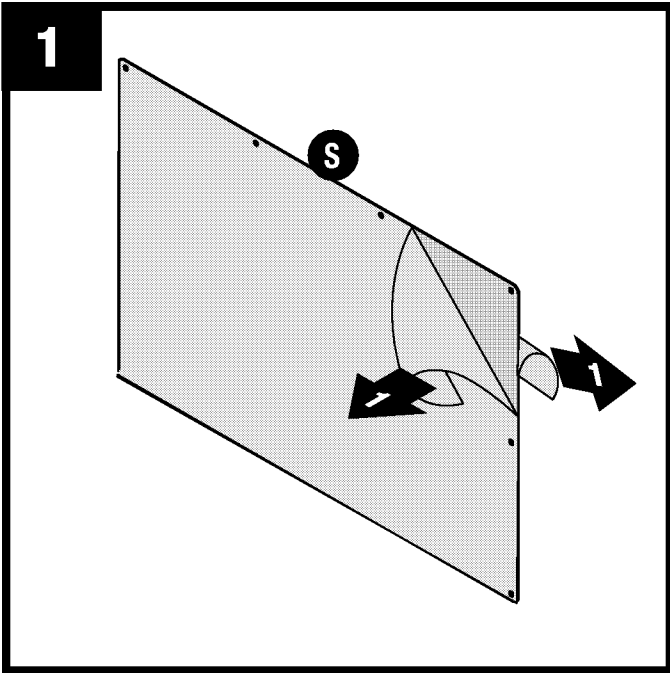

Peel film from both sides of window (S).

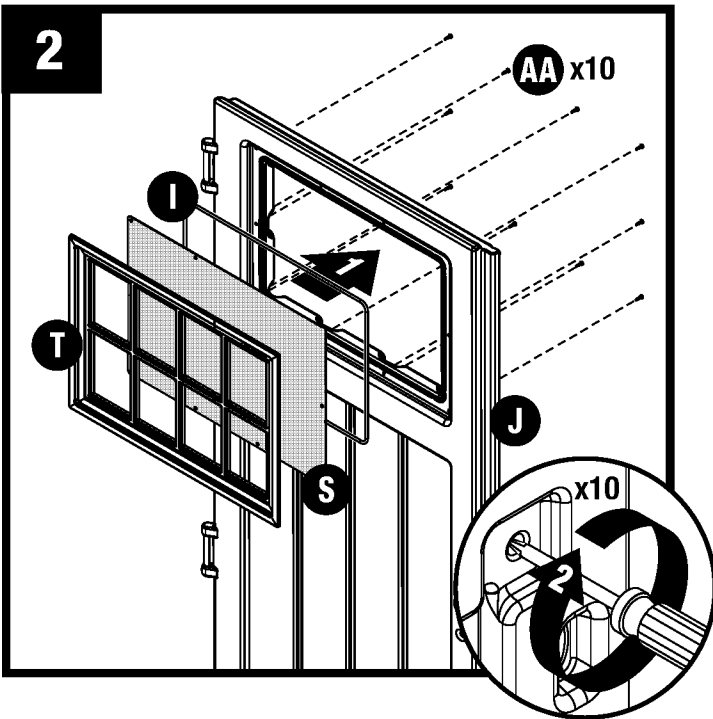

Stand left door (J) vertically. In this order, layer into door channel the door window gasket (I), door window (S), and door window frame (T). From the back of door, secure layers with ten screws (AA) (start with four corner screws and then finish with remaining screws).

DO NOT over tighten screws. Repeat steps 1 and 2 for right door (K).

Note: The cut portion of window gasket (I) **MUST** be assembled on bottom of door channel.



Note: At least two people are needed during assembly.

Door Pre-Assembly (continued)

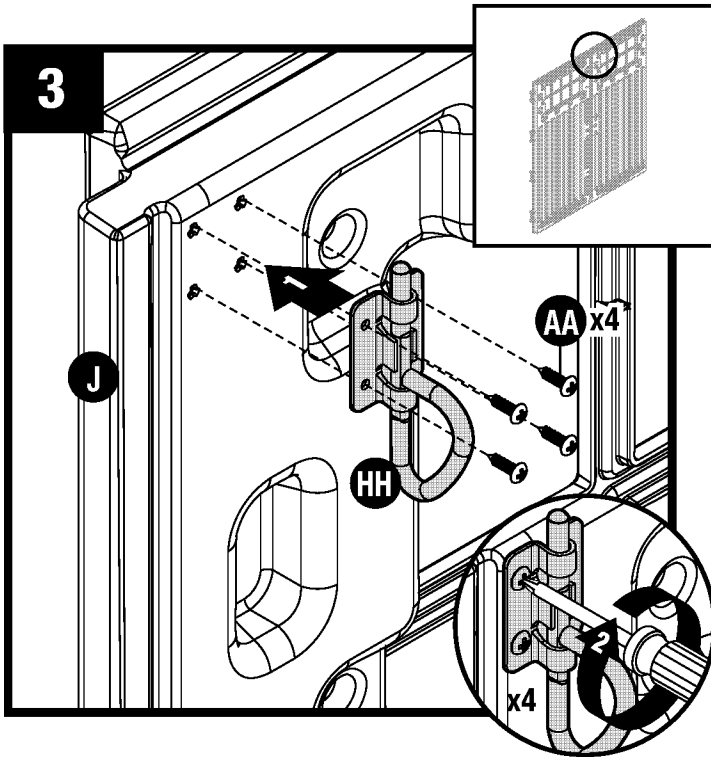

At top interior side of left door (J), attach D-ring slide bolt (HH) with four screws (AA) through provided holes.

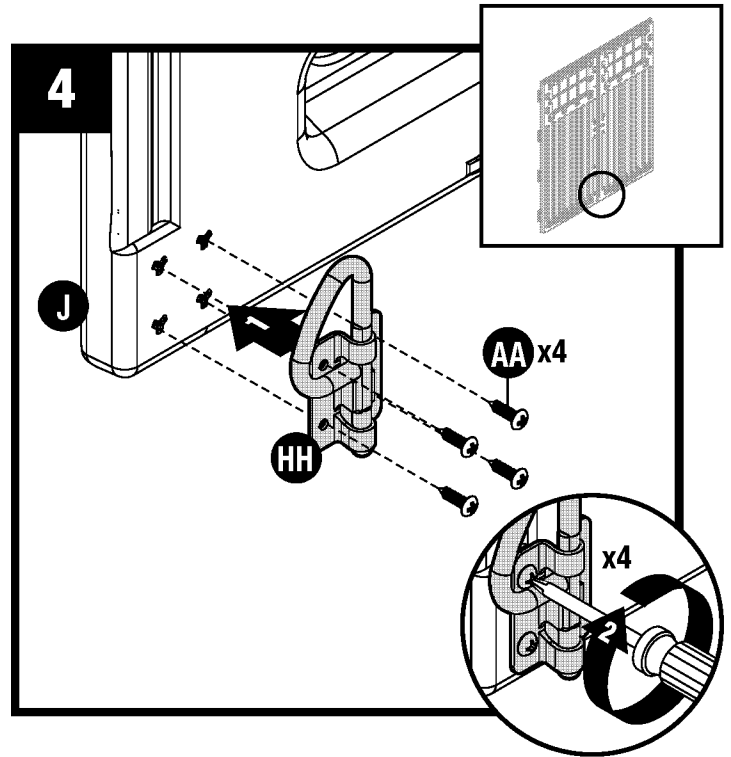

At bottom interior side of left door (J), attach D-ring slide bolt (HH) with four screws (AA) through provided holes.

Front Header Pre-Assembly

Parts/hardware needed for header pre-assembly are shown on pages 7 and 8.

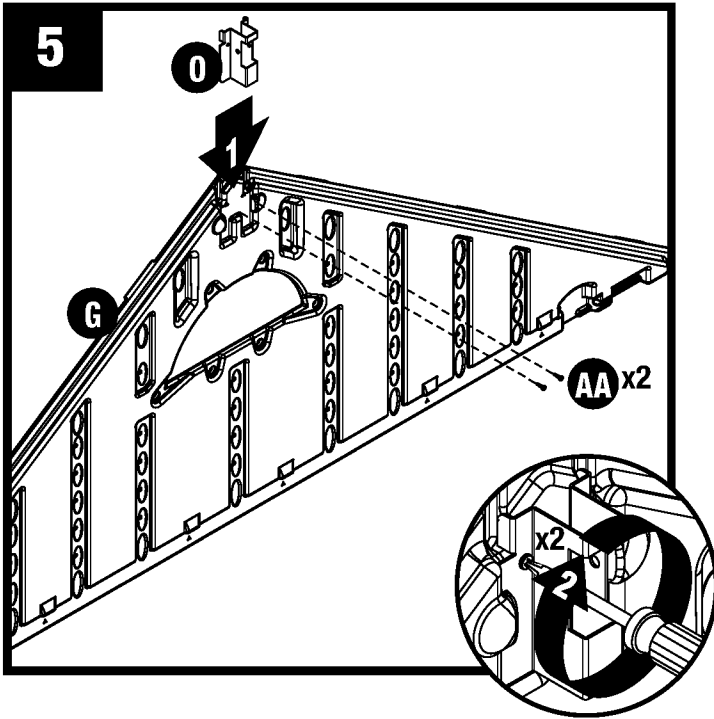

Slide roof ridge beam bracket (O) under tabs on the inside peak of the front header (G) and secure with two screws (AA). **DO NOT** over tighten screws.

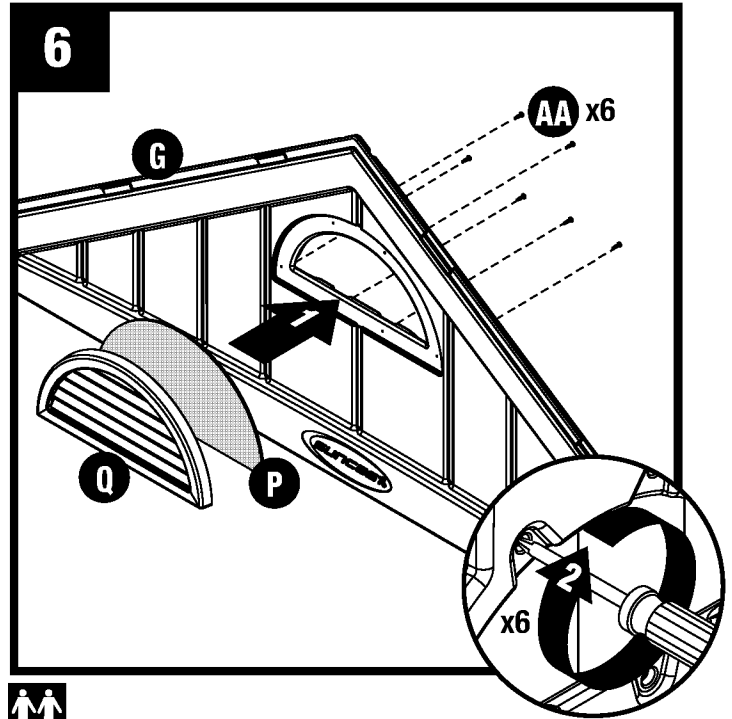

Place vent screen (Q), followed by header vent (P) into front opening in front header (G). Secure through back of header with six screws (AA). **DO NOT** over tighten screws.

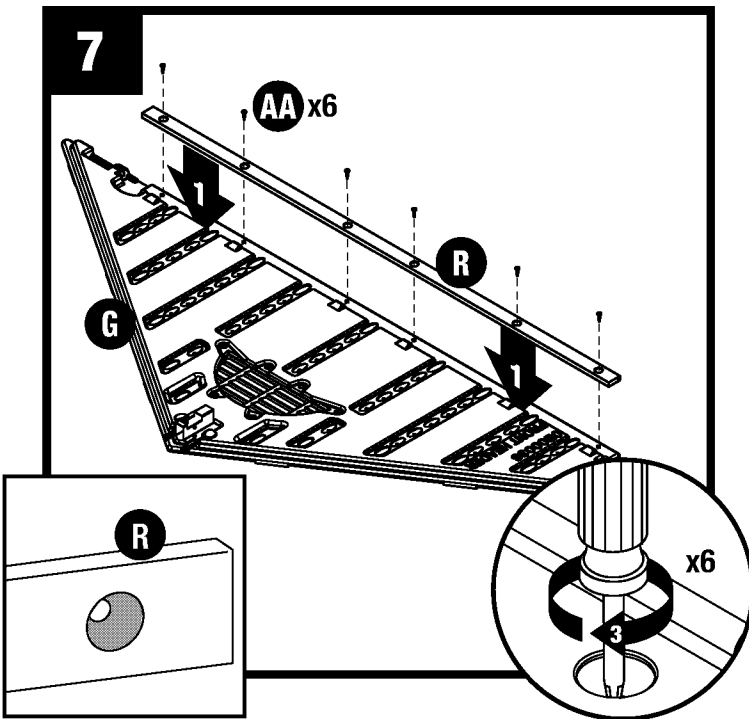

Lay front header (G) on ground with lettering side facing up. Place one header beam (R) into pocket on inside of front header (G). Attach with six screws (AA). **DO NOT** over tighten screws.

Note: Header beam (R) has large holes on one side and small holes on other side. The small holes must face header.

Rear Header Pre-Assembly

Parts/hardware needed for header pre-assembly are shown on pages 7 and 8.

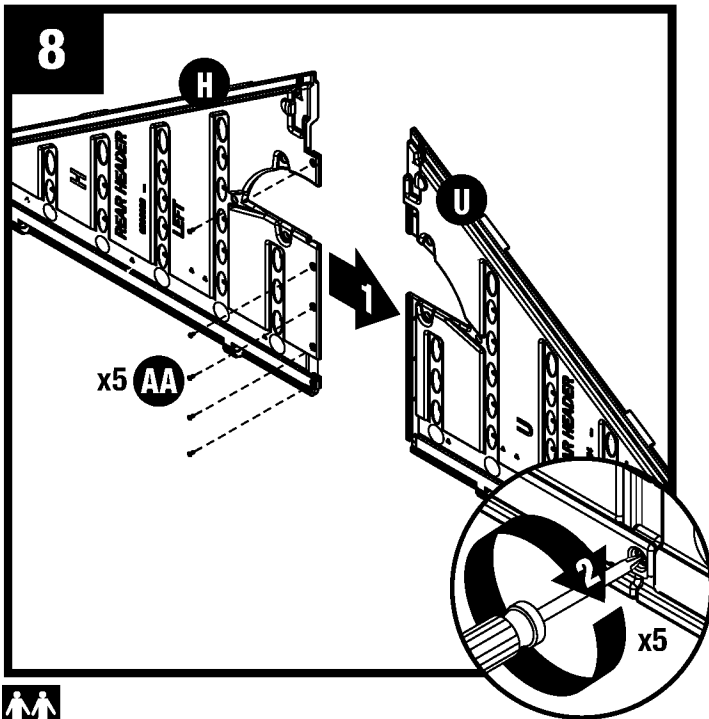

Join left rear header (H) to right rear header (U). Hold halves together and secure with five screws (AA). **DO NOT** over tighten screws.

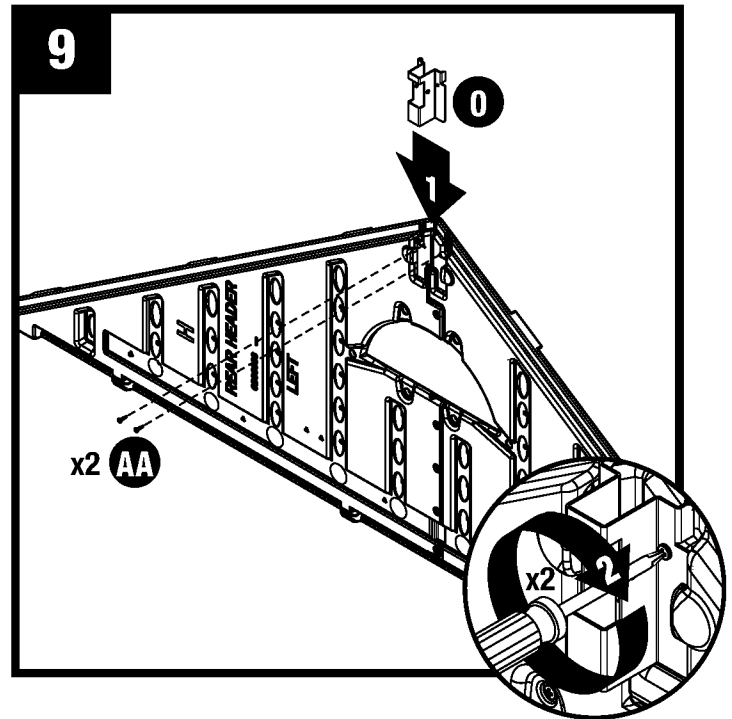

Slide remaining roof ridge beam bracket (O) under the tabs on the inside peak of the rear header assembly. Secure with two screws (AA). **DO NOT** over tighten screws.

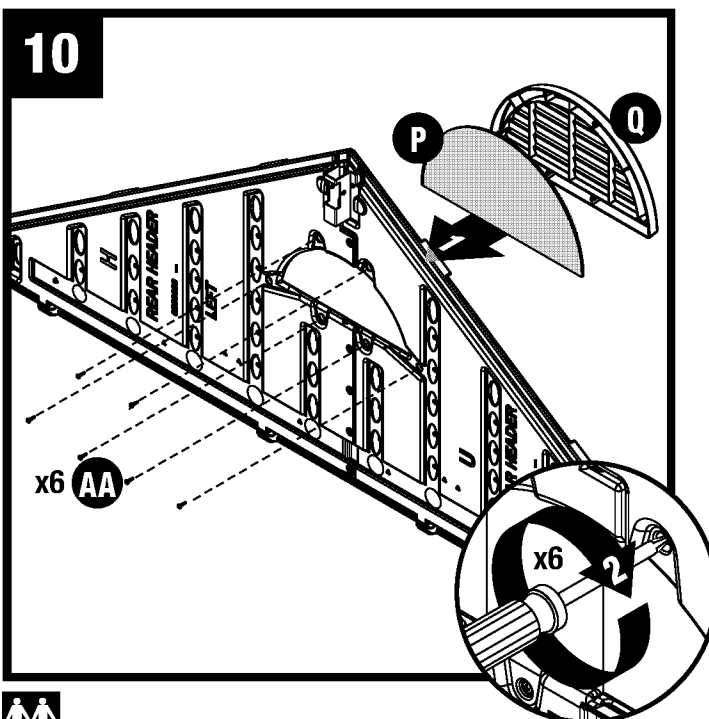

Place vent screen (P), followed by header vent (Q) into front opening in rear header. Secure through back of header with six screws (AA). **DO NOT** over tighten screws.

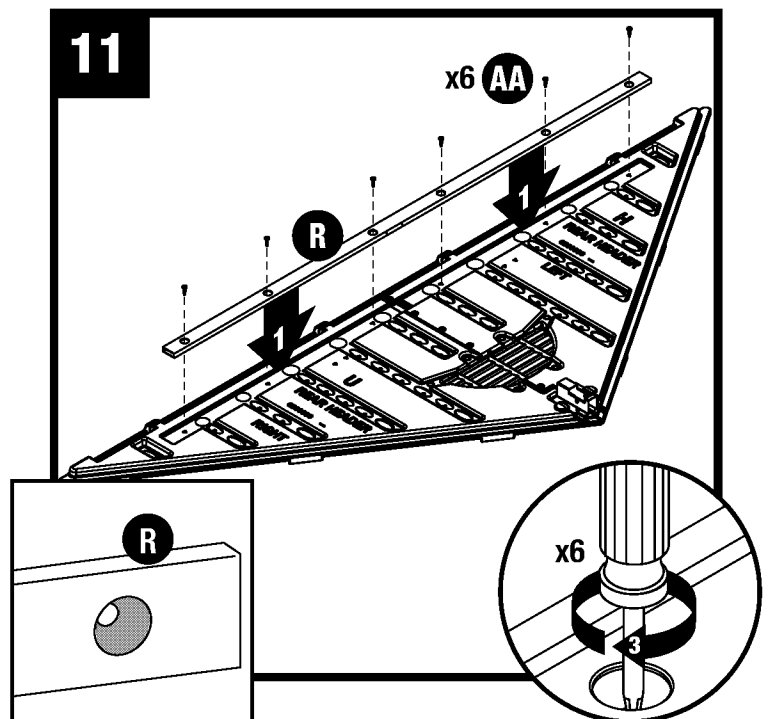



Lay rear header on ground with lettering side facing up. Place one header beam (R) into pocket on inside of rear header. Attach with six screws (AA). **DO NOT** over tighten screws.

Note: Header beam (R) has large holes on one side and small holes on other side. The small holes must face header.

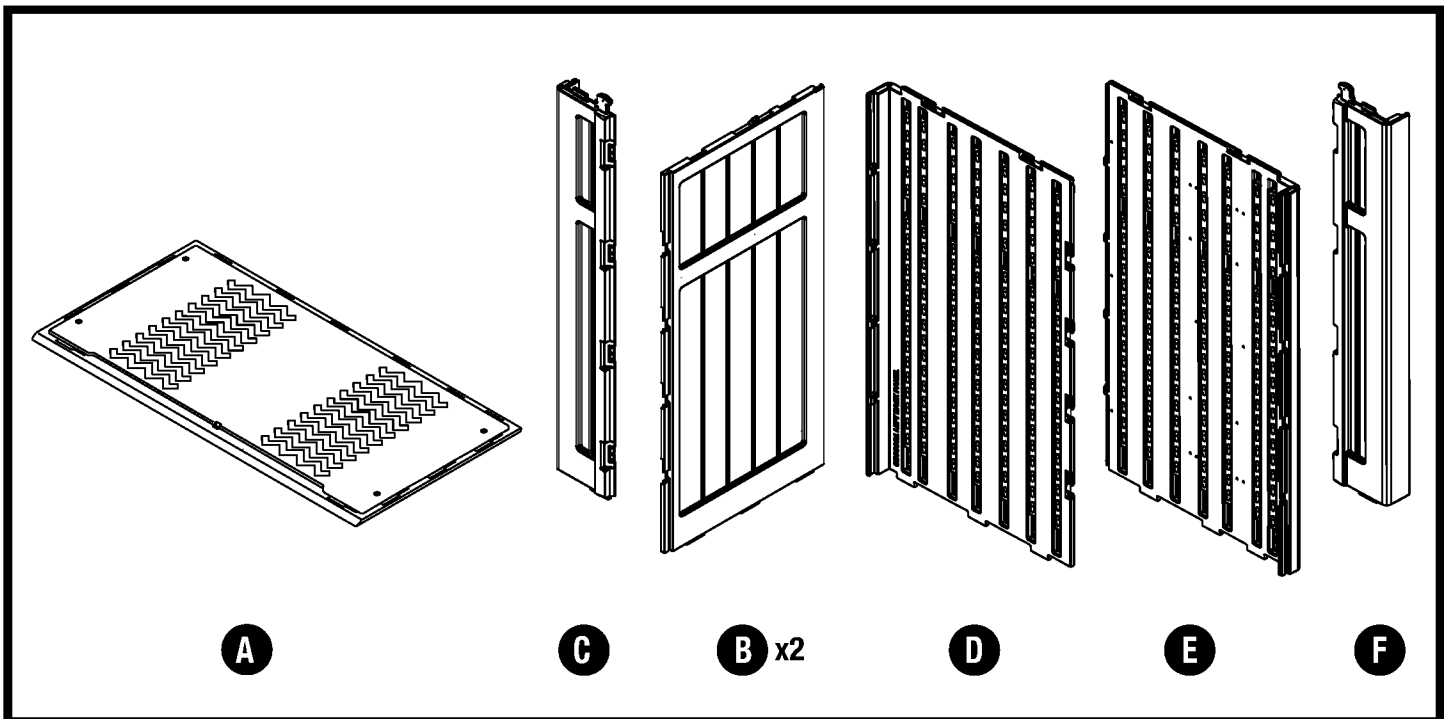
Shed Assembly/Walls



 **Note:** At least two people are needed during assembly.

 **Note:** Need to use a rubber mallet.

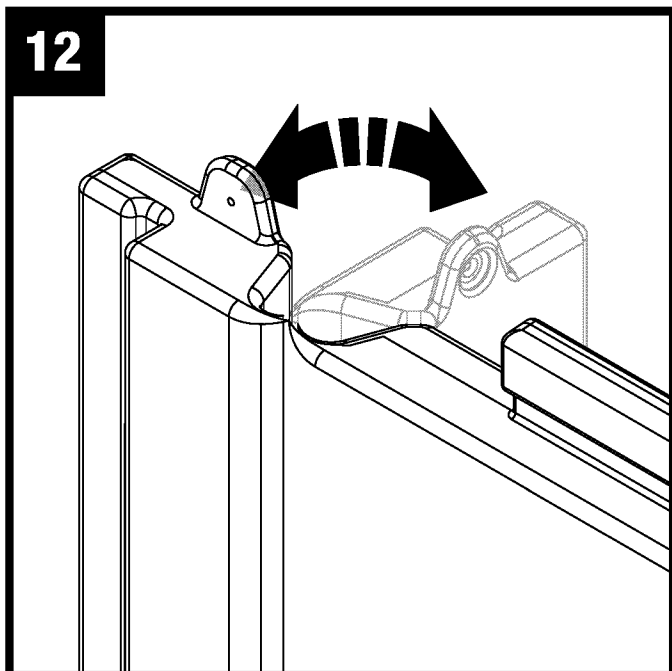

Critical: When installing corners, flex corner hinges back and forth several times. This will help provide a square corner and ensure proper fit of remaining panels.

Important: DO NOT flex in reverse position, as this can crack the panel.

Shed Assembly/Walls (continued)

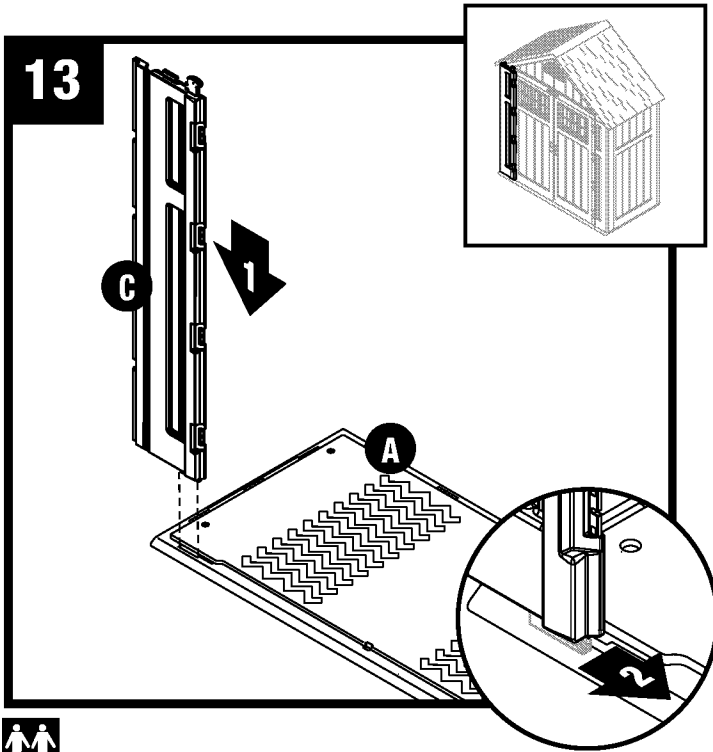

Align tab on bottom of left front panel (C) with slot on floor (A) front. Lower panel into slot and lock in place by sliding panel toward door opening.

Note: Use a rubber mallet to “push” left front panel (C) into locked position.

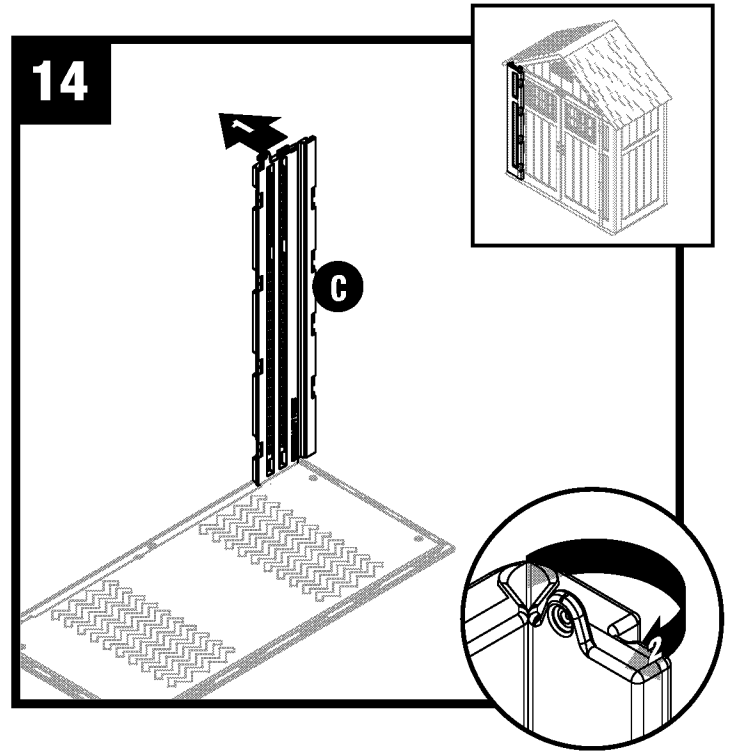

Tip left front panel (C) outward slightly and bend corner hinge.

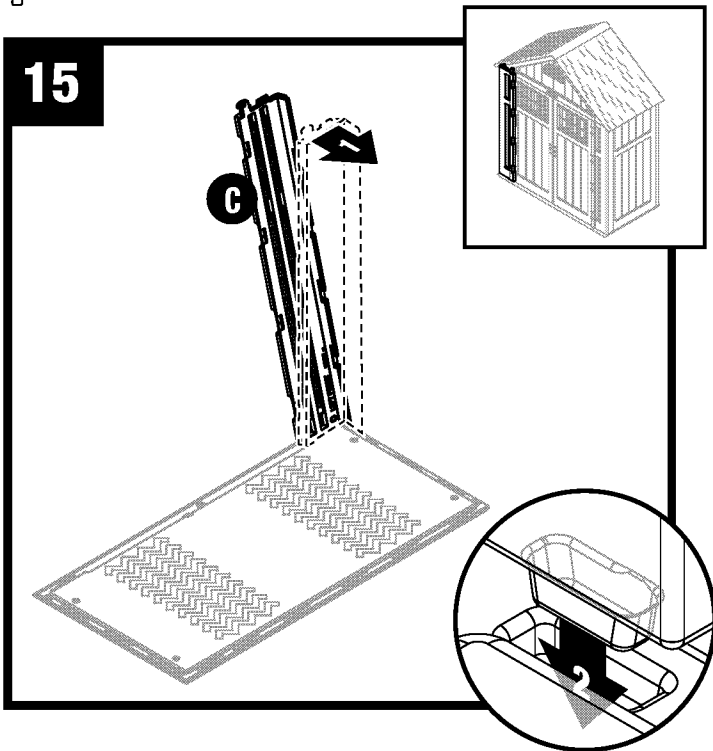

Tip left front panel (C) back to vertical position and align lower tabs on right side with slots in floor.

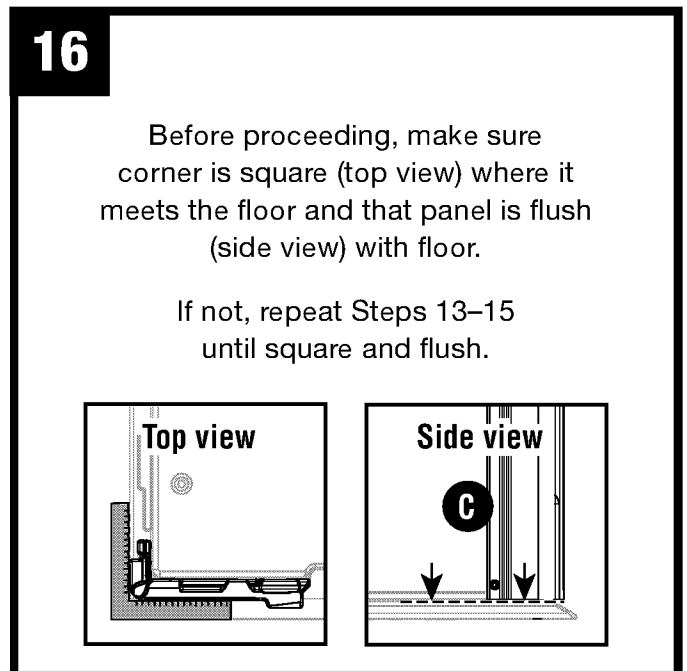

Shed Assembly/Walls (continued)

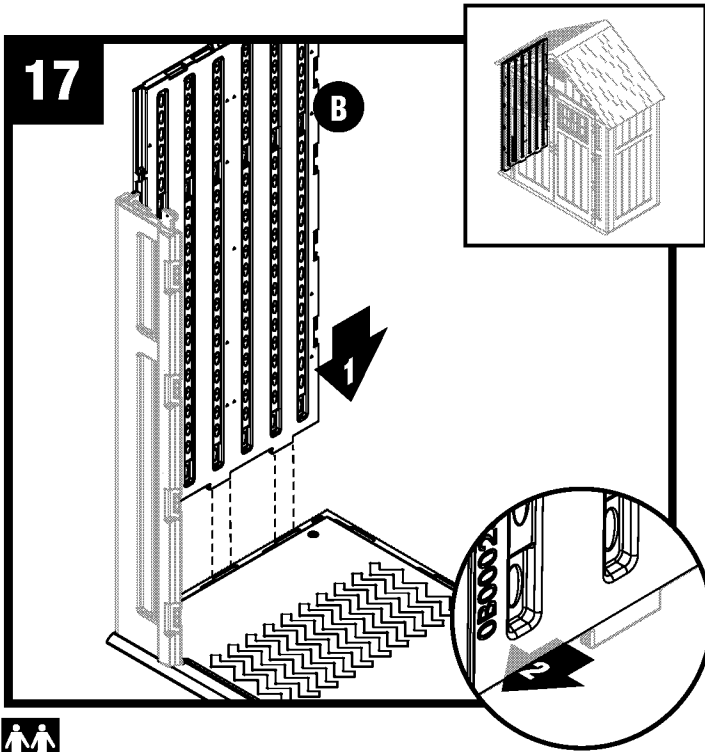

Align tabs on bottom of side panel (B) with slots along floor side. Lower panel into slots and lock in place by sliding panel toward front.

Note: Use a rubber mallet to “push” side panel (B) into locked position.

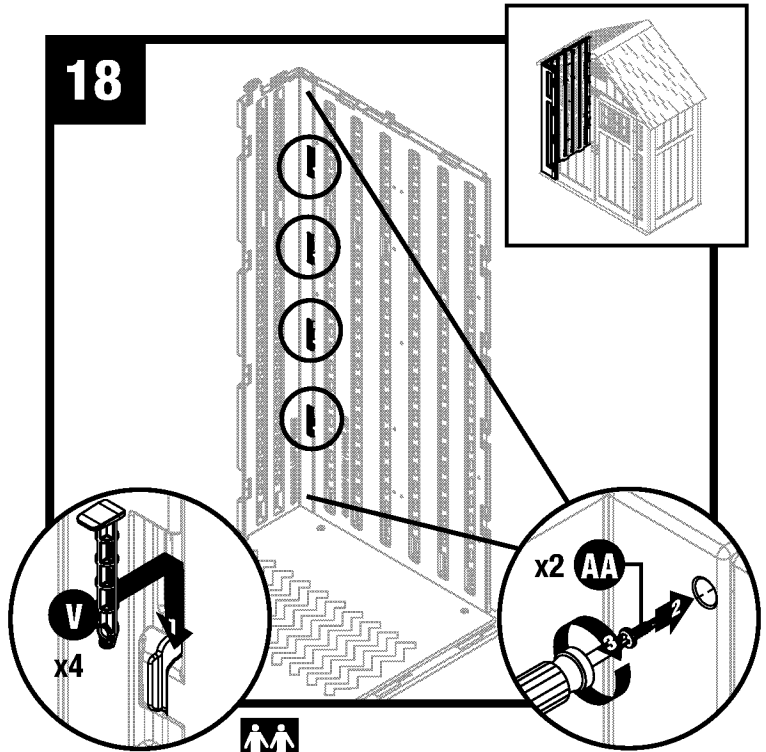

Secure with four panel connector pins (V). From the outside, push the edge of side panel to help align pins. Install one screw (AA) at top and bottom of overlap.

DO NOT over tighten screws.

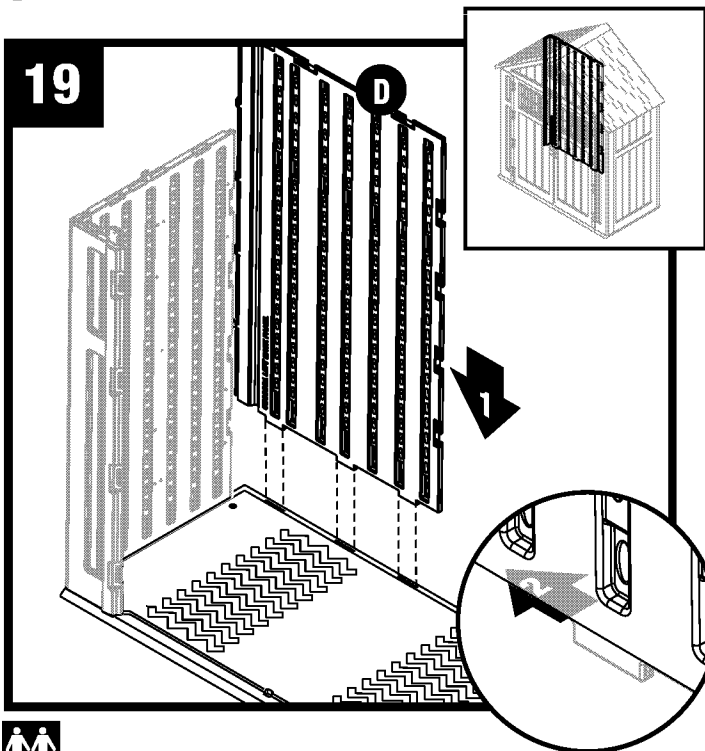

Align tab on bottom of left back panel (D) with slot on floor rear. Lower panel into slot and lock in place by sliding panel toward corner.

Note: Use a rubber mallet to “push” left back panel (D) into locked position.

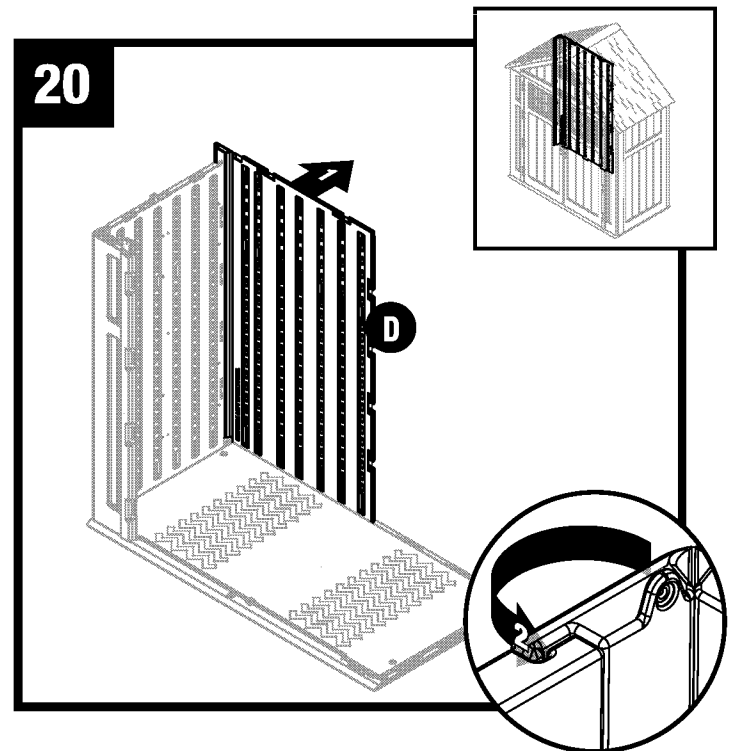

Tip left back panel (D) outward slightly and bend corner hinge.

Shed Assembly/Walls (continued)

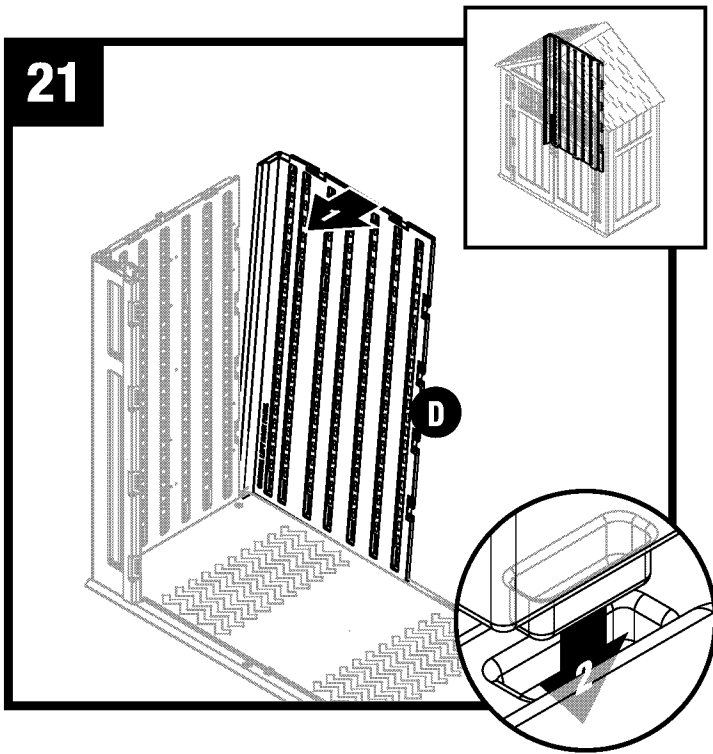

Tip left back panel (D) back to vertical position and align lower tabs on right side with slots in floor.

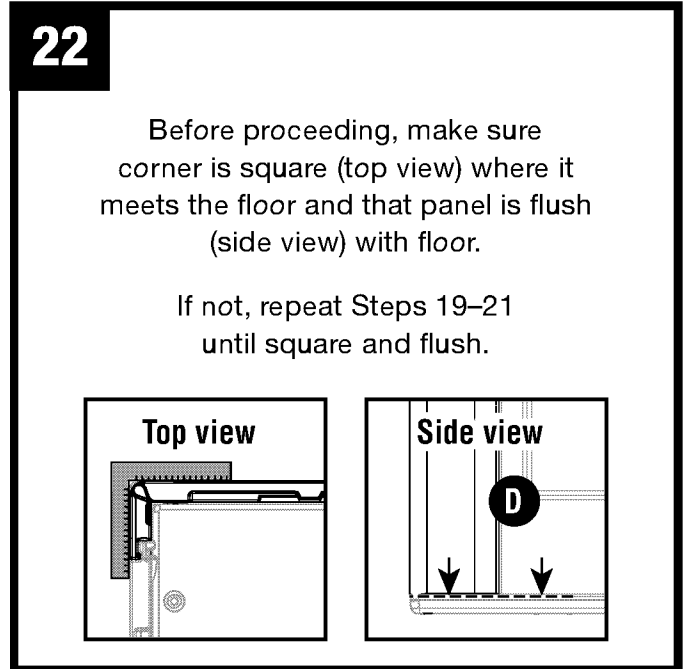

Before proceeding, make sure corner is square (top view) where it meets the floor and that panel is flush (side view) with floor.

If not, repeat Steps 19–21 until square and flush.

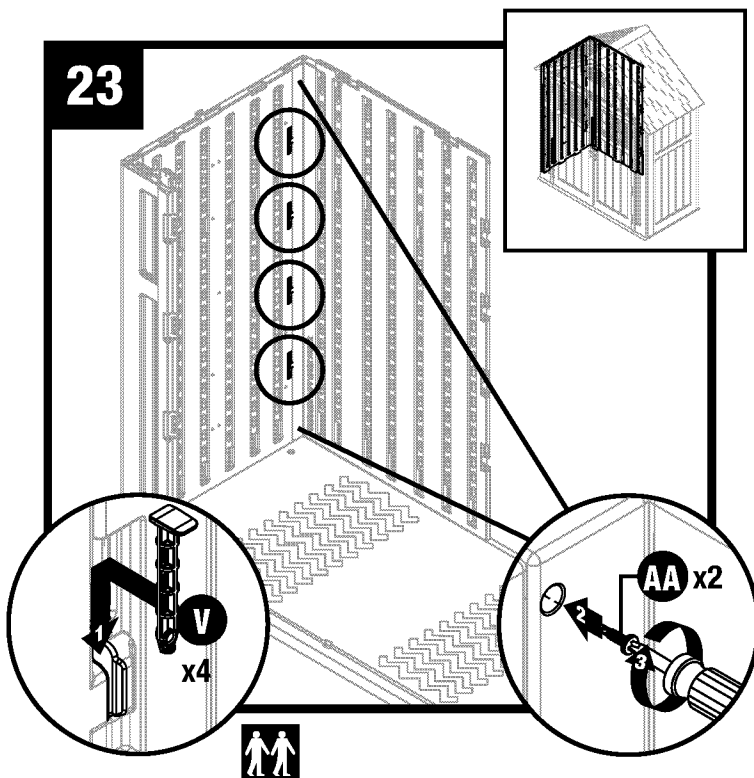

Secure with four panel connector pins (V). From the outside, push the edge of left back panel to help align pins. Install one screw (AA) at top and bottom of overlap. **DO NOT** over tighten screws.

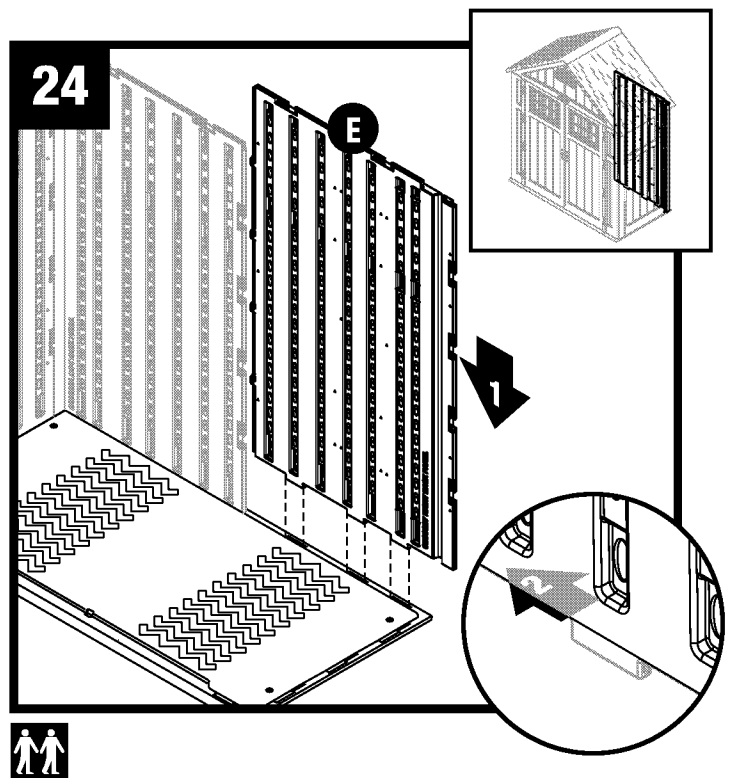

Align tab on bottom of right back panel (E) with slot on floor rear. Lower panel into slot and lock in place by sliding panel toward corner.

Note: Use a rubber mallet to “push” right back panel (E) into locked position.

Shed Assembly/Walls (continued)

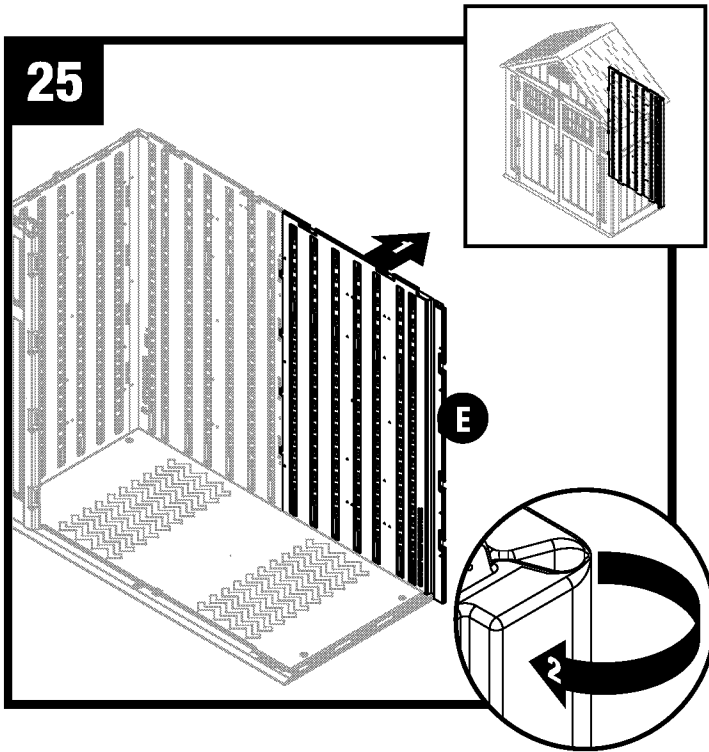

Tip right back panel (E) outward slightly and bend corner hinge.

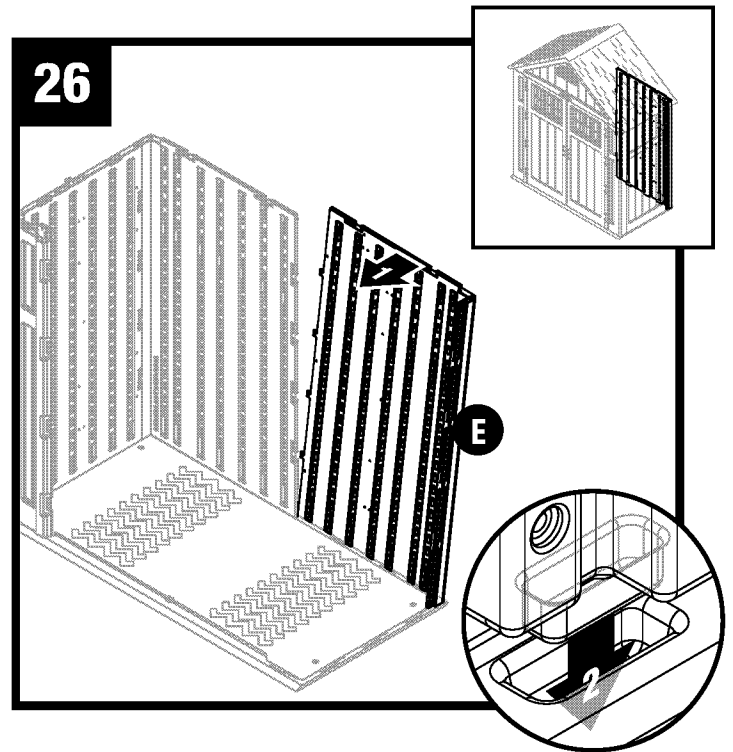

Tip right back panel (E) back to vertical position and align lower tabs on right side with slots in floor.

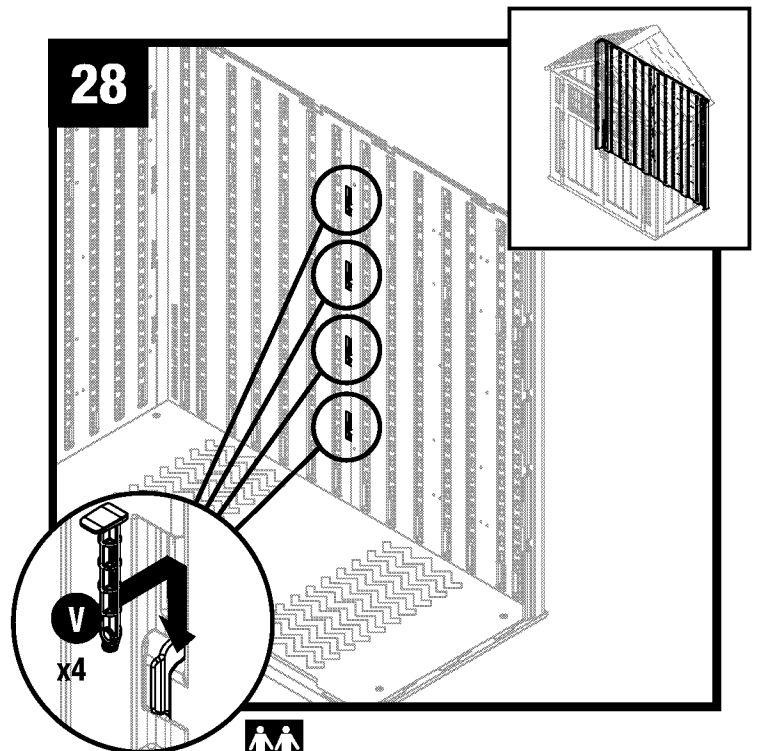
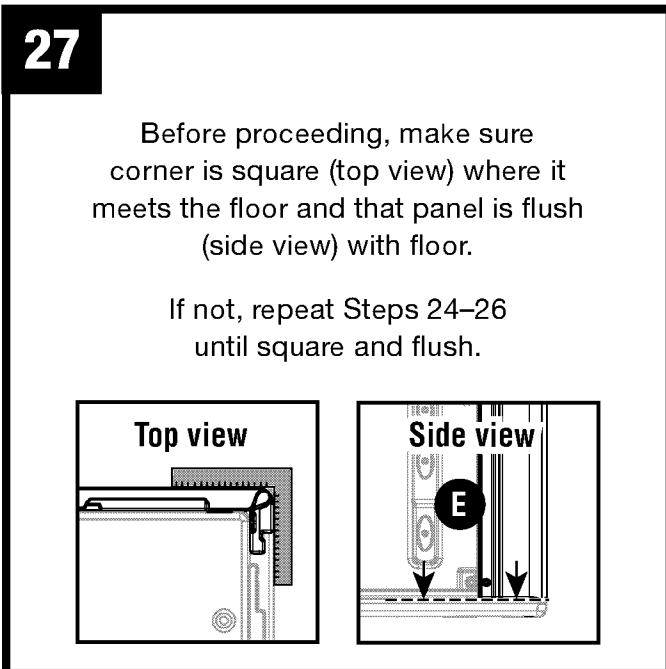

Secure with four panel connector pins (V). From the outside, push the edge of side panel to help align pins.

Shed Assembly/Walls (continued)

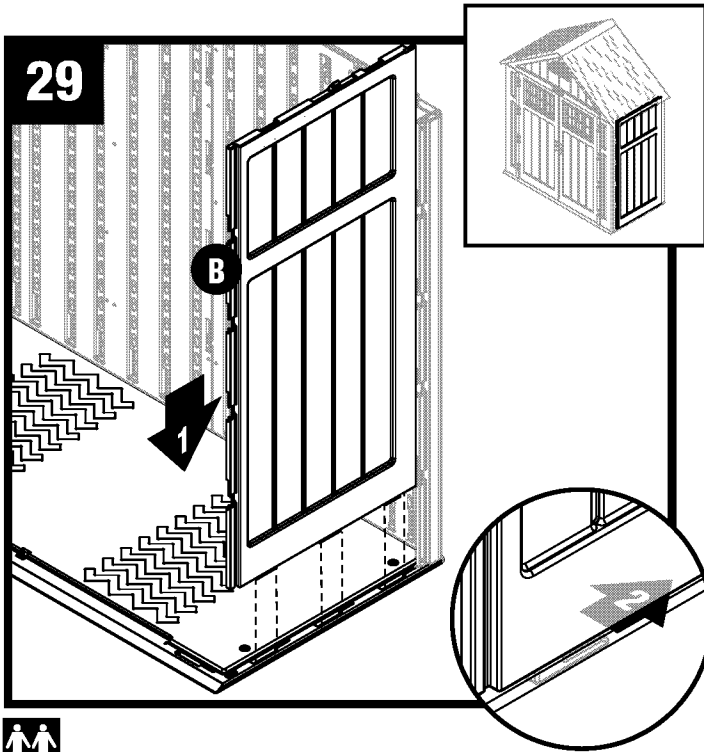

Align tabs on bottom of side panel (B) with slots along right side floor. Lower panel into slots and lock in place by sliding panel toward rear.

Note: Use a rubber mallet to “push” side panel (B) into locked position.

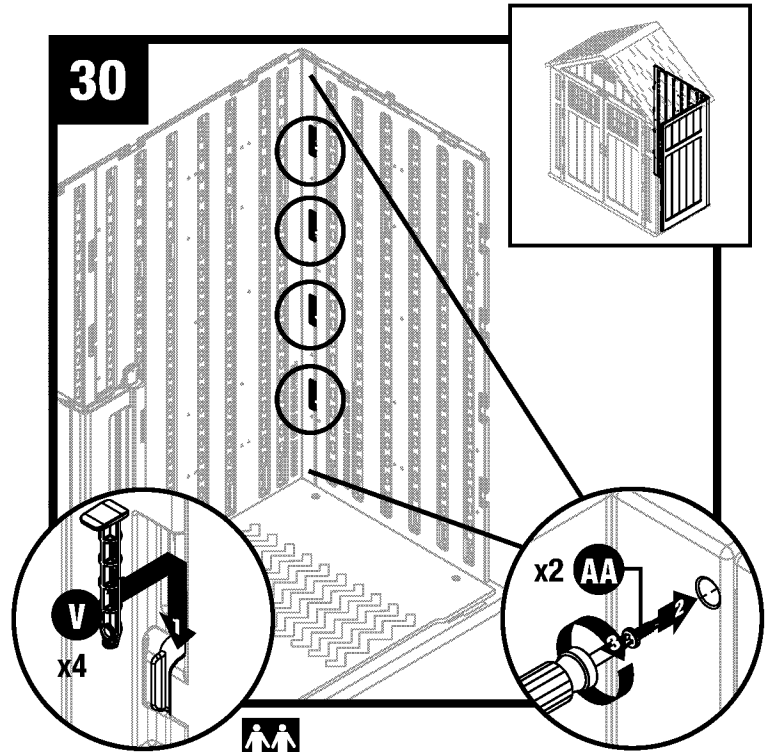

Secure with four panel connector pins (V). From the outside, push the edge of right back panel to help align pins. Install one screw (AA) at top and bottom of overlap. **DO NOT** over tighten screws.

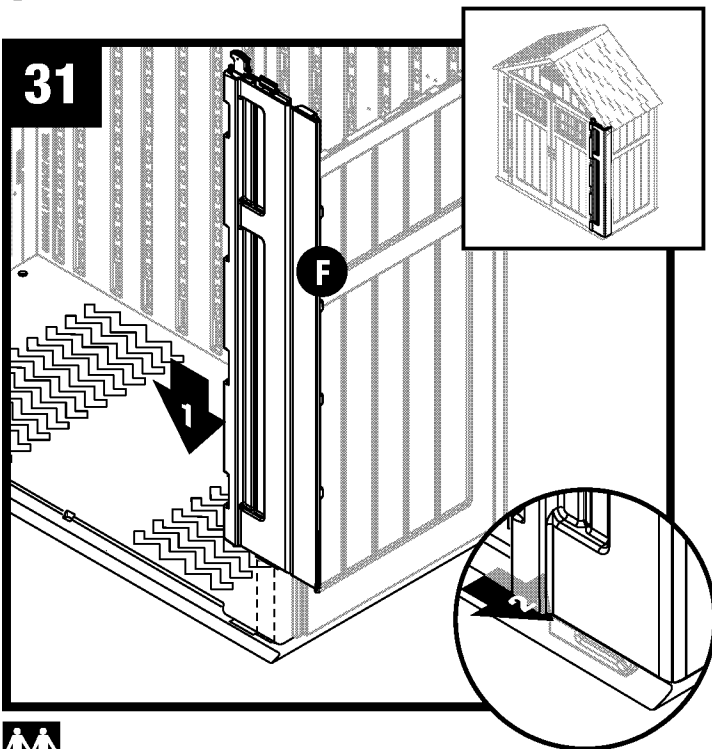

Align tabs on bottom of right front panel (F) with slots along floor front. Lower panel into slots and lock in place by sliding panel toward door opening.

Note: Use a rubber mallet to “push” right front panel (F) into locked position.

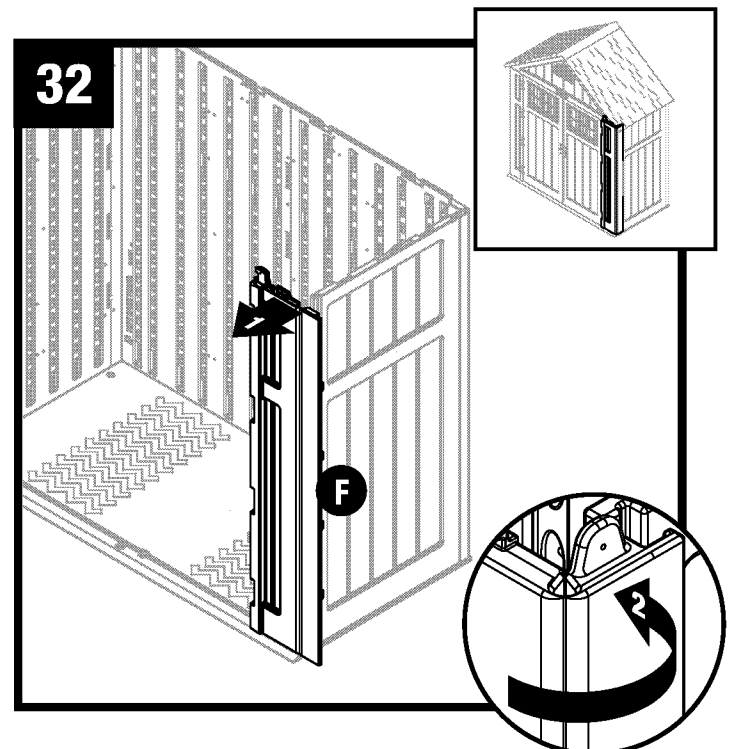

Tip right front panel (F) outward slightly and bend corner hinge.

Shed Assembly/Walls (continued)

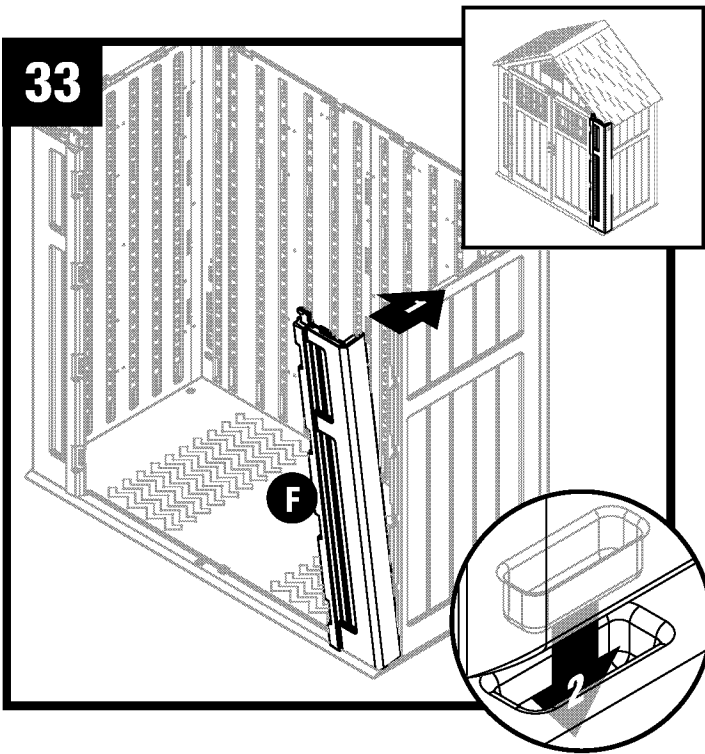

34

Before proceeding, make sure corner is square (top view) where it meets the floor and that panel is flush (side view) with floor.

If not, repeat Steps 31–33 until square and flush.

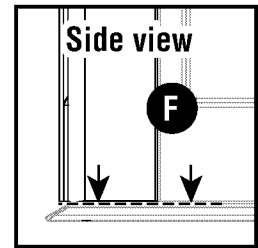
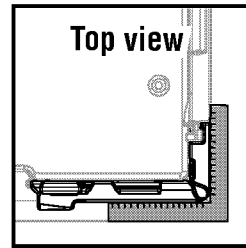

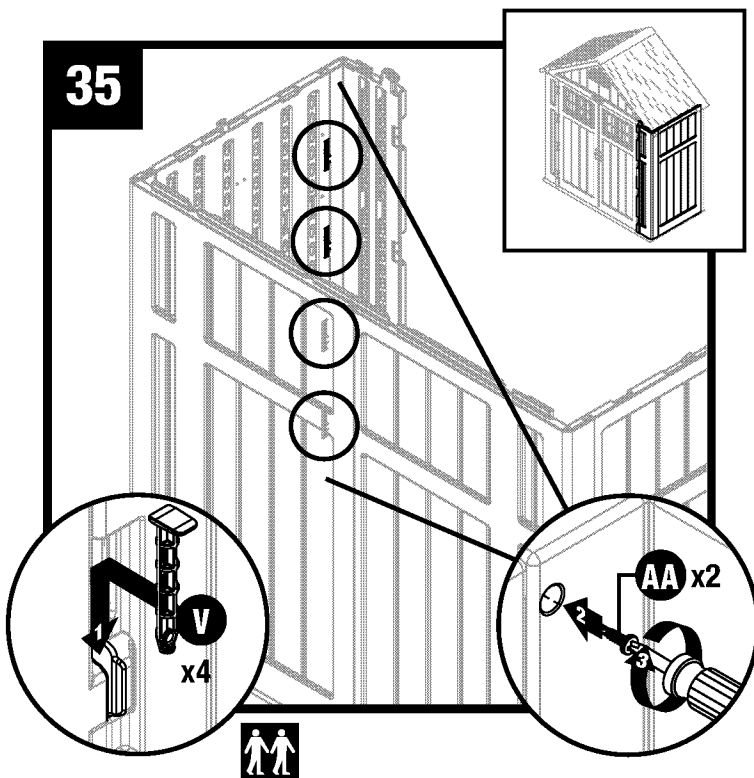

Tip right front panel (F) back to vertical position and align lower tabs on right side with slots in floor.

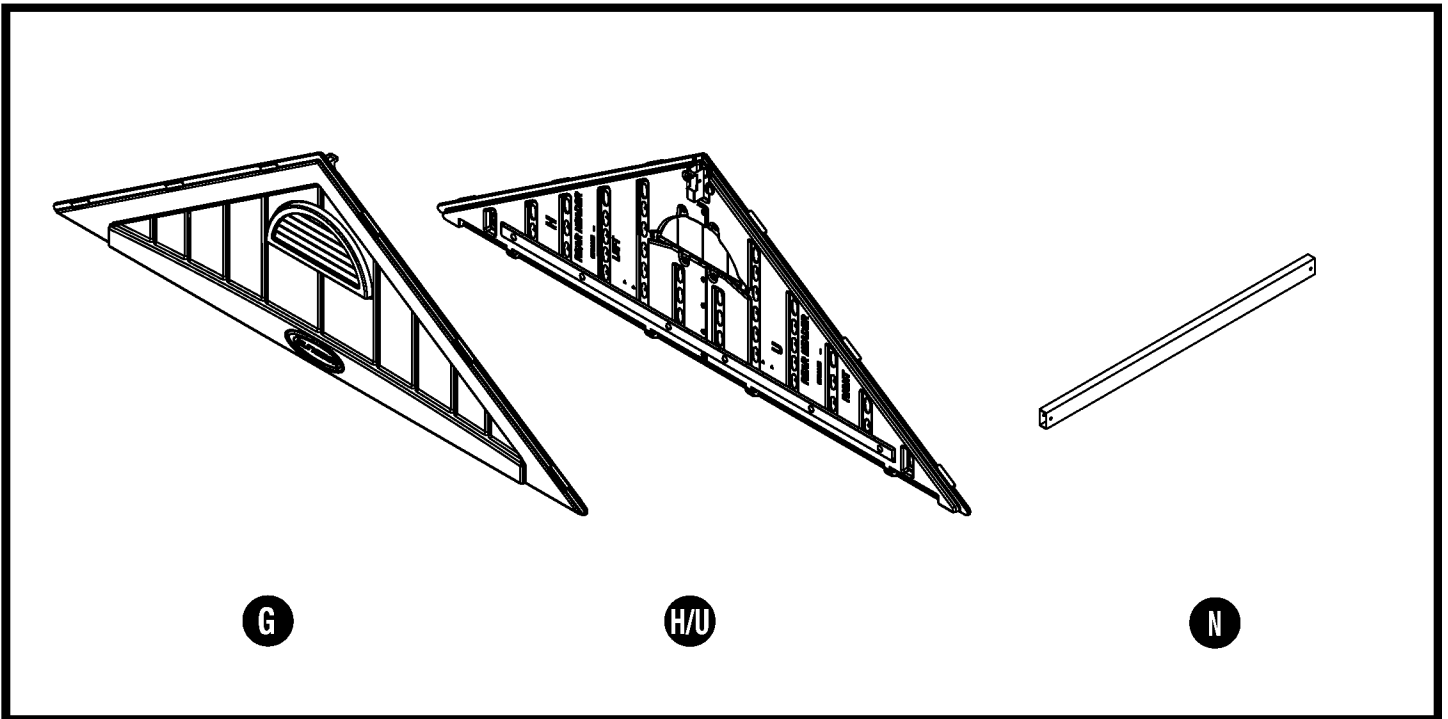

Secure corner with four panel connector pins (V). From the outside, push the edge of side panel to help align pins. Install one screw (AA) at top and bottom of overlap. **DO NOT** over tighten screws.

Shed Assembly/Headers and Truss



 **Note:** At least two people are needed during assembly.

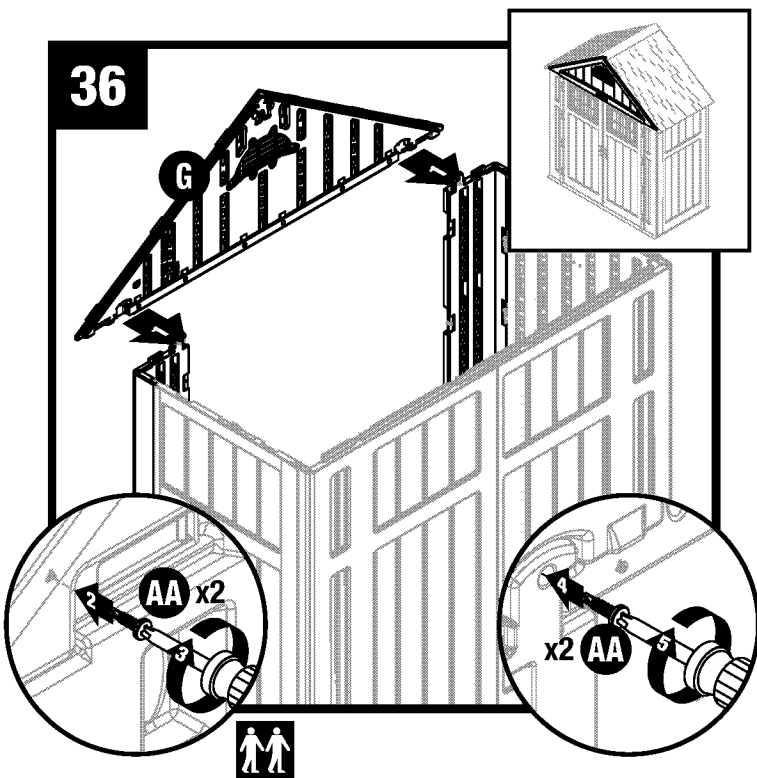

Place front header (G) over door opening and fit two protruding support legs on the left and right front panels into pockets molded in header panel. Secure support legs in the pockets using two screws (AA) in each leg.

Note: *DO NOT* leave header unsupported until beam assembly is complete (step 39).

Shed Assembly/Headers and Truss (continued)

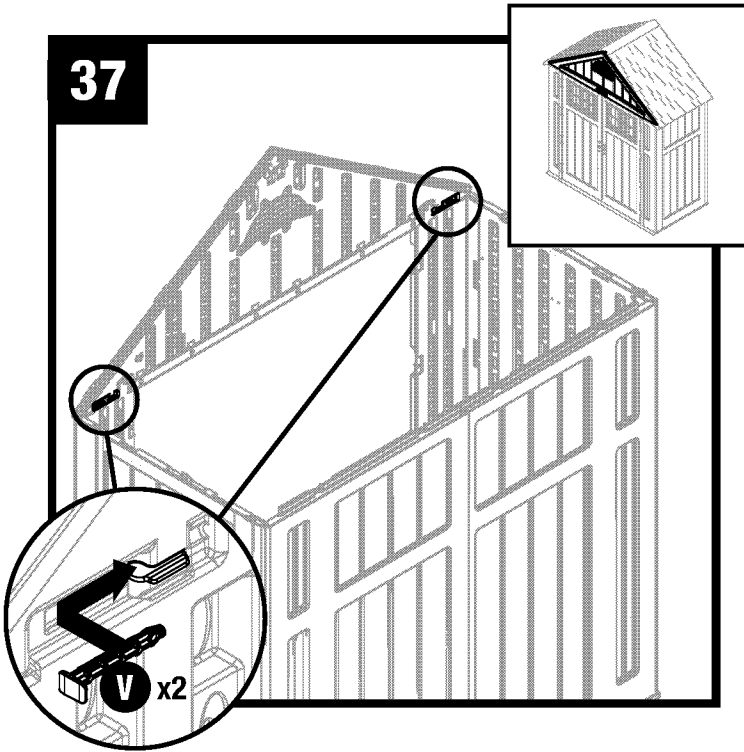

Secure front header with two panel connector pins (V).

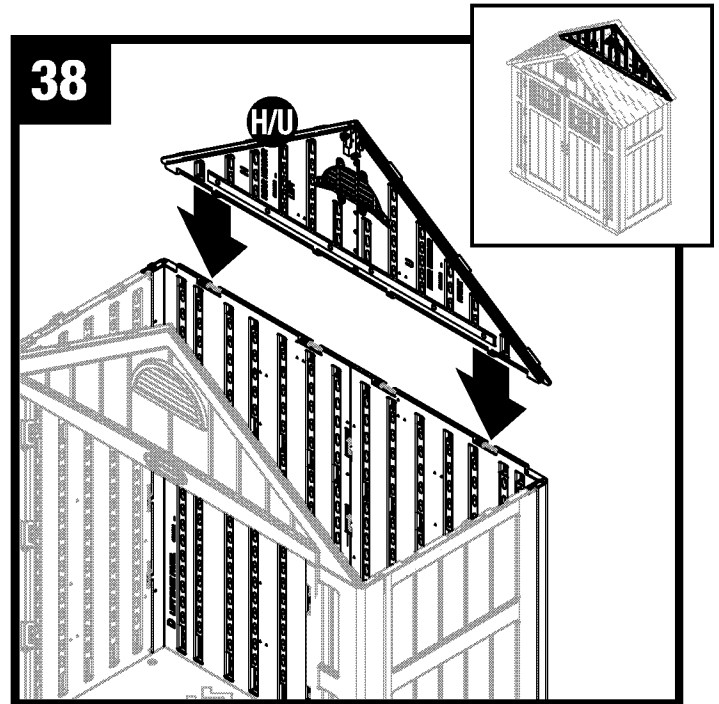

Place the rear header assembly (H/U) on top of the back panel wall.

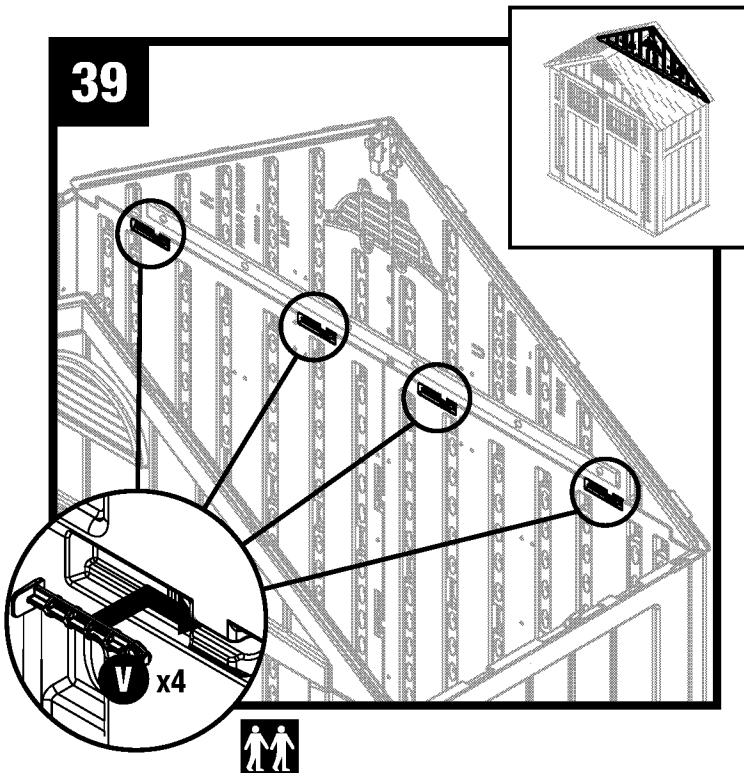

Secure header assembly with four panel connector pins (V).

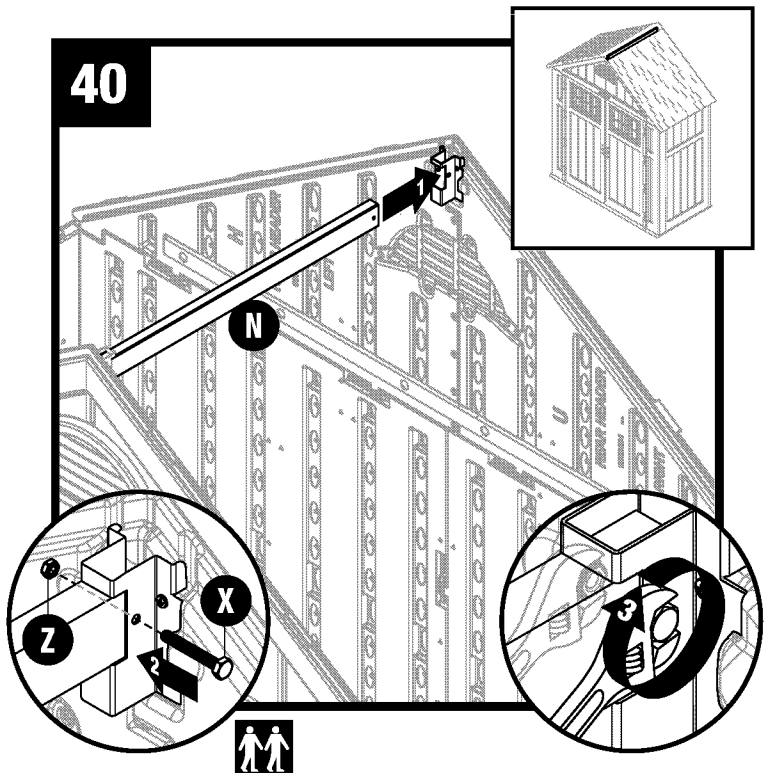

Raise the ridge beam (N) up and into the rear roof ridge beam bracket. Secure with one 2" hex bolt (X) and one nut (Z).

Note: Alignment of ridge beam to bracket may require header panels to be pushed inwards or outwards slightly as ridge beam is slid into place.

Shed Assembly/Headers and Truss (continued)

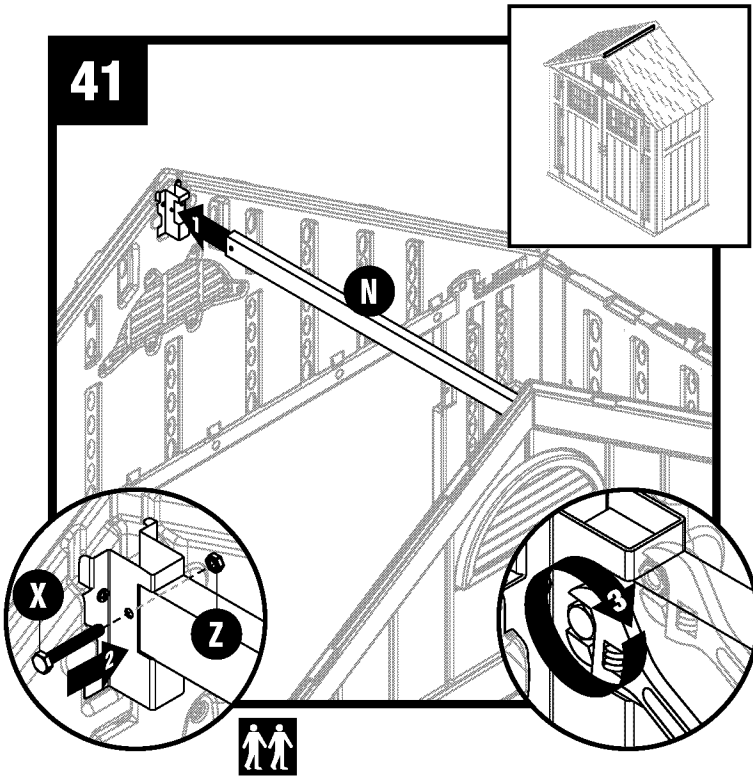



Push the ridge beam (N) toward the rear to clear the front roof ridge beam bracket. Then, insert beam into front bracket. Secure with one 2" hex bolt (X) and one nut (Z).

Note: Alignment of ridge beam to bracket may require header panels to be pushed inwards or outwards slightly as ridge beam is slid into place.

CAUTION: Be very careful positioning ridge beam to avoid harm to persons or damage to property. **DO NOT** stand beneath beam until it is secured with screws and nuts.

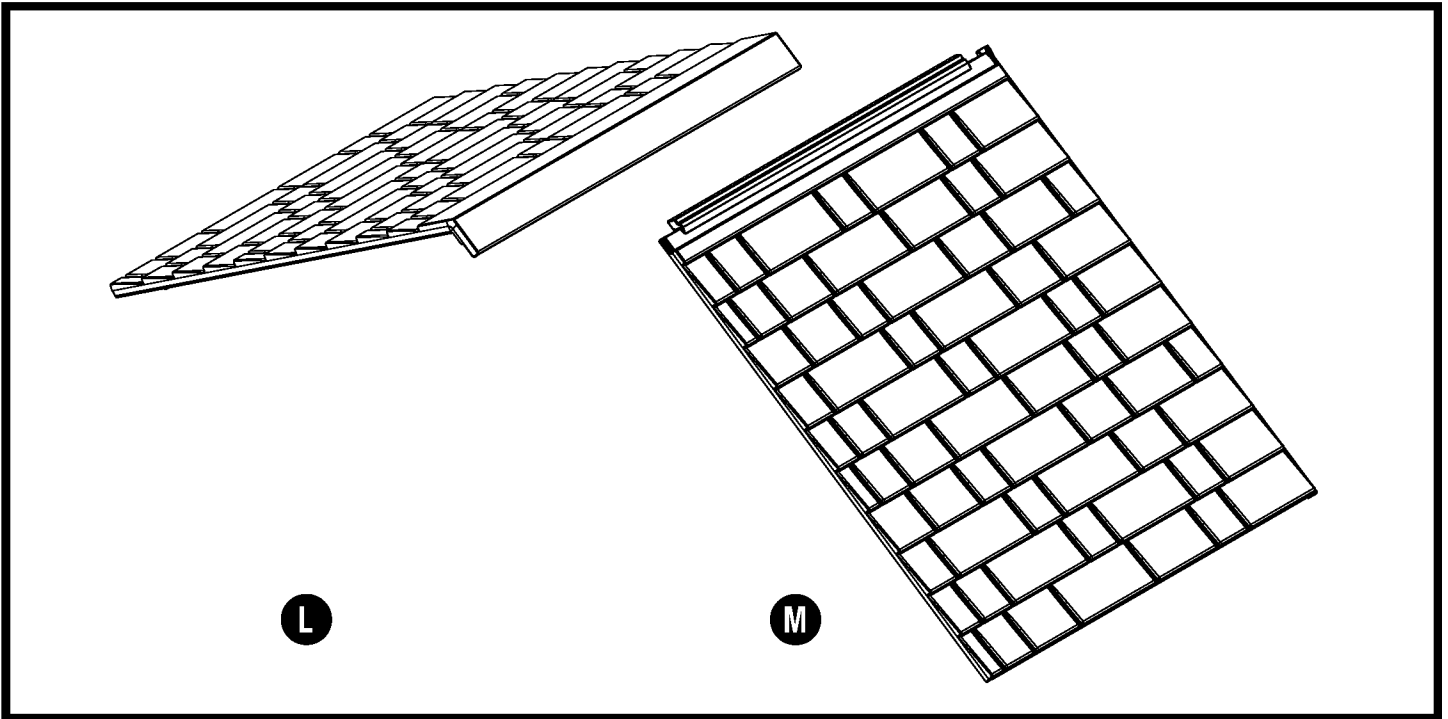
Shed Assembly/Roof



 **Note:** At least two people are needed during assembly.

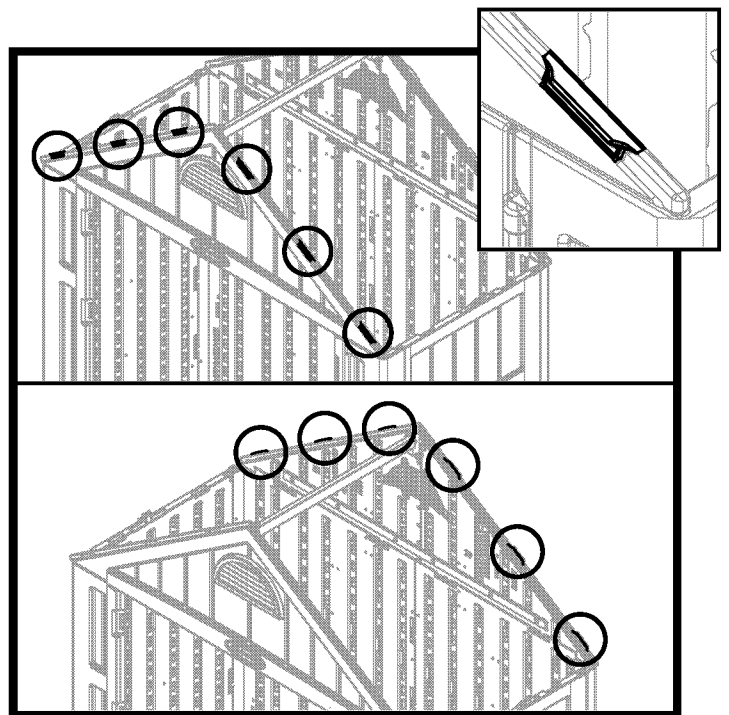
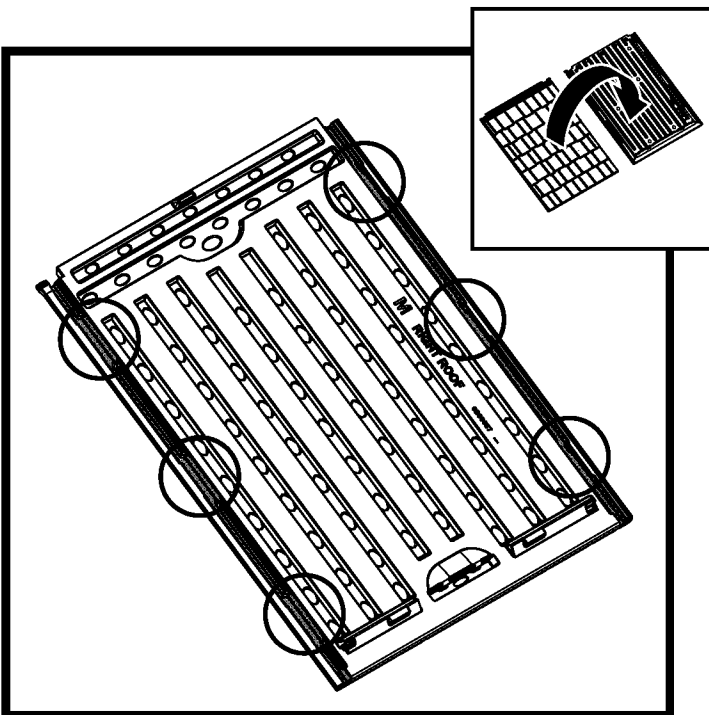

Before proceeding, locate and identify channels on interior side of right roof (M) and left roof (L). Locate three underside tabs contained within each channel.

Before proceeding, locate and identify six front header tabs and six rear header tabs.

Shed Assembly/Roof (continued)

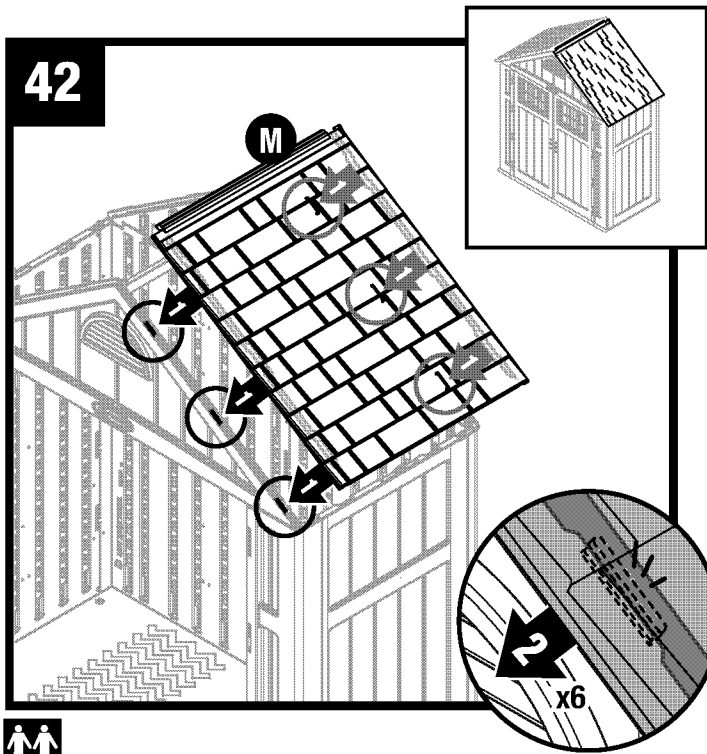

Lay right roof (M) directly over three tabs on right side of front header. With roof panel channel seated over/on header tabs, pull roof downward at each header tab until roof snaps in place.

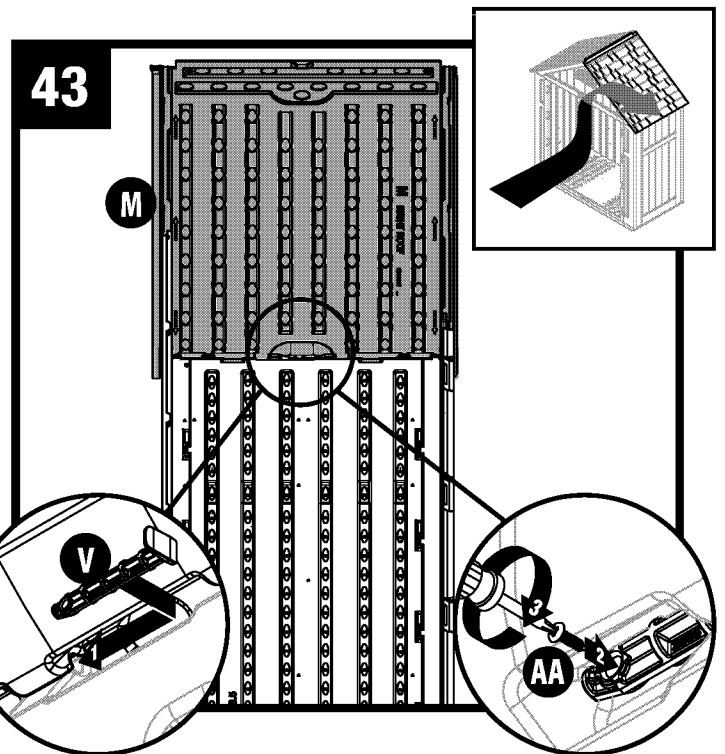

From inside shed, secure right roof panel (M) into place using panel connector pin (V) on side panel. Slide panel connector towards rear of shed until fully engaged. Attach panel connector pin with one screw (AA).

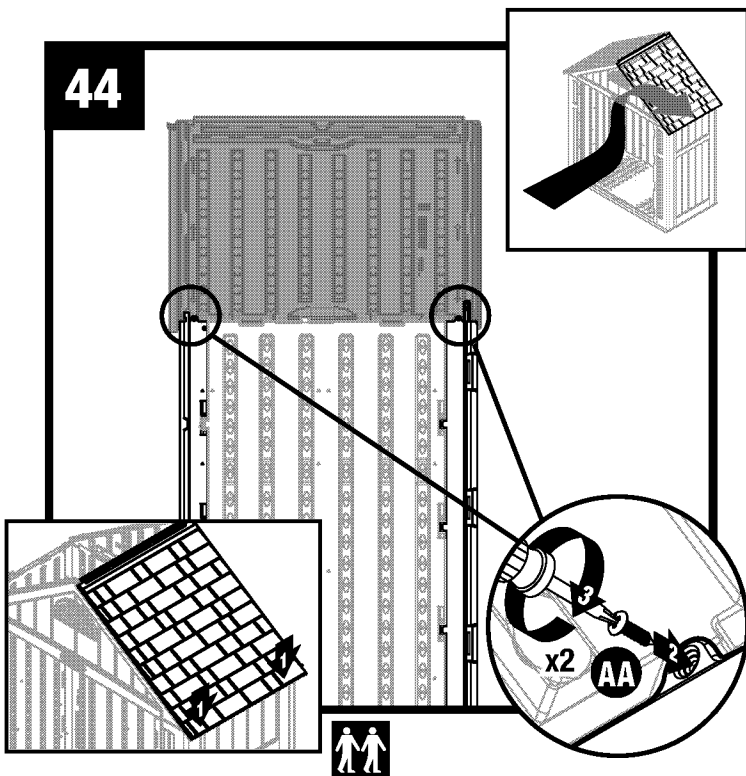

Pull down each lower corner of roof from outside. From inside shed, attach each tab to the corresponding roof panel with one screw (AA).

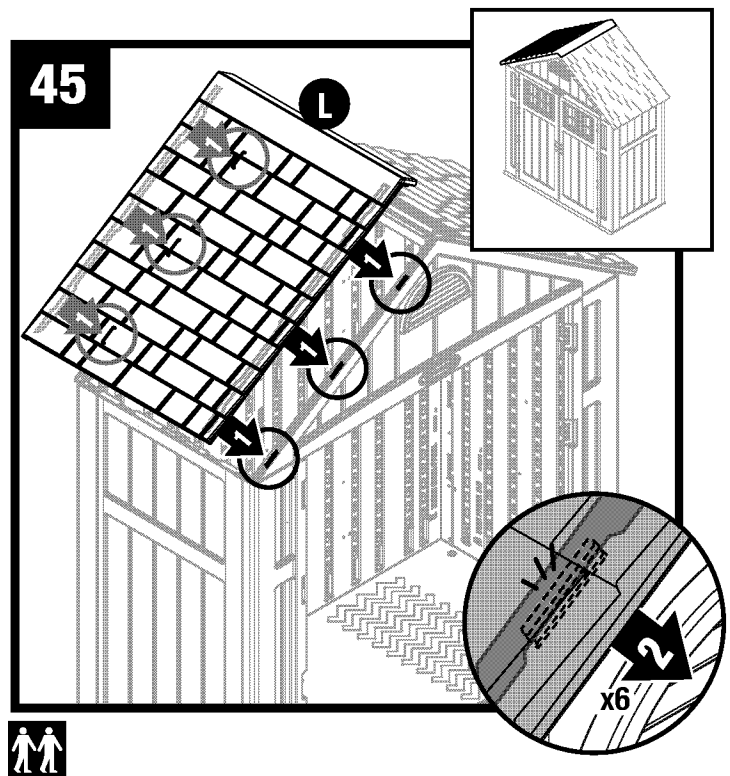

Lay left roof (L) directly over three tabs on left side of front header. With roof panel channel seated over/on header tabs, pull roof downward at each header tab until roof snaps in place.

Shed Assembly/Roof (continued)

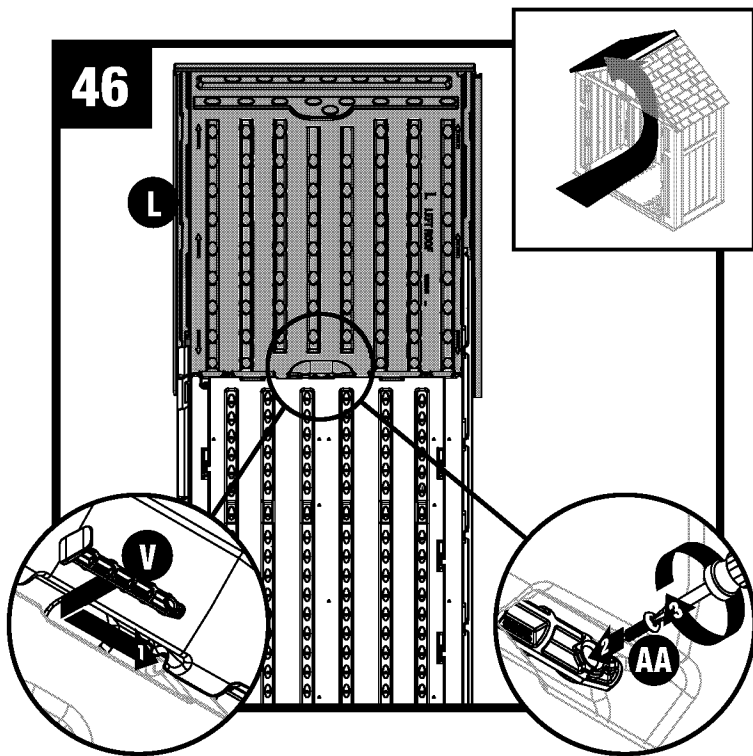

From inside shed, secure left roof panel (L) into place using panel connector pin (V) on side panel. Slide panel connector towards rear of shed until fully engaged. Attach panel connector pin with one screw (AA).

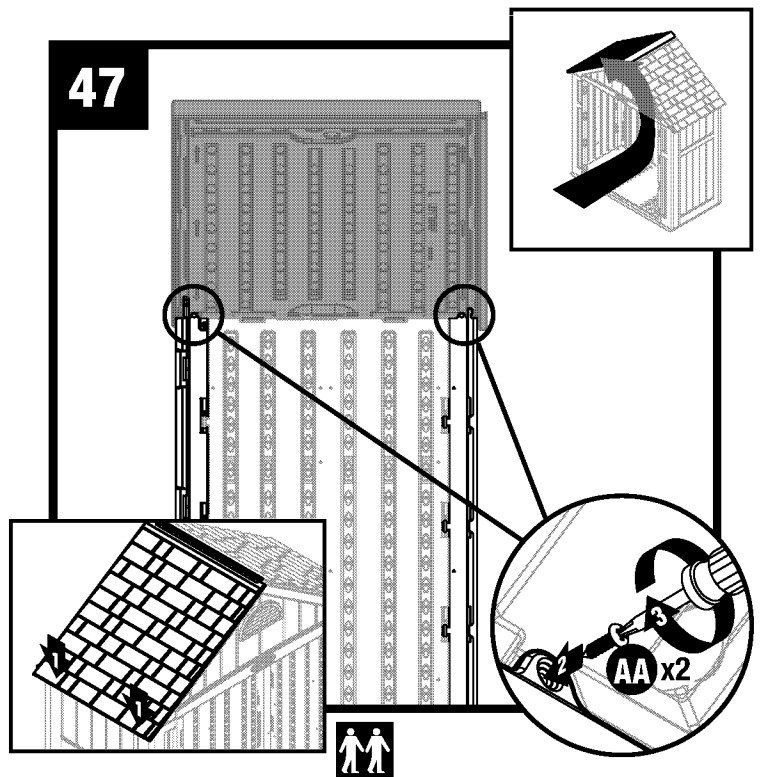

Pull down each lower corner of roof from outside. From inside shed, attach each tab to the corresponding roof panel with one screw (AA).

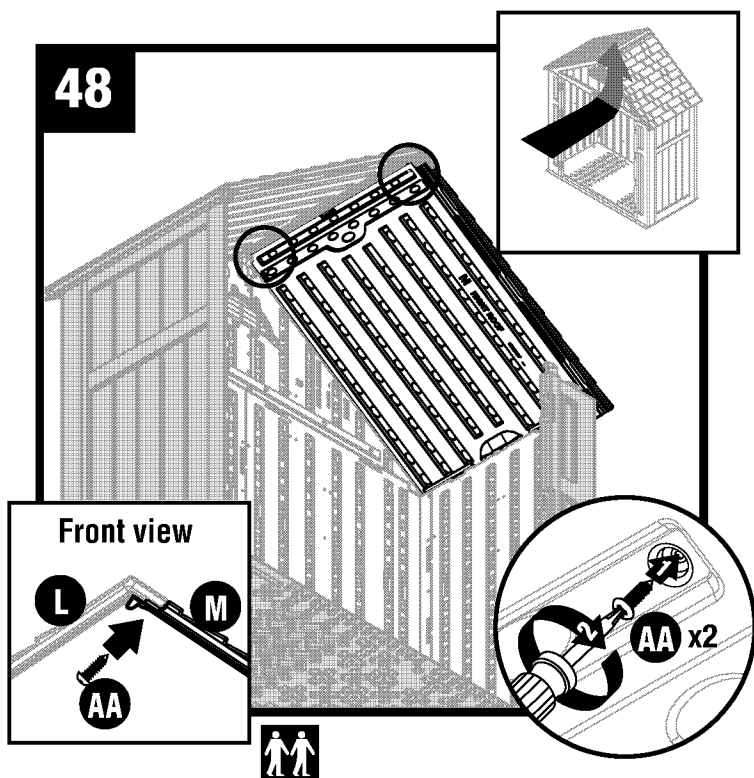



From inside the shed, attach two screws (AA) through holes in each right roof panel (M) into each left roof panel (L) to secure roof assembly.

Note: Have a second person push down roof from outside.

Note: For clarity, illustration is shown with front header and left front panel removed.

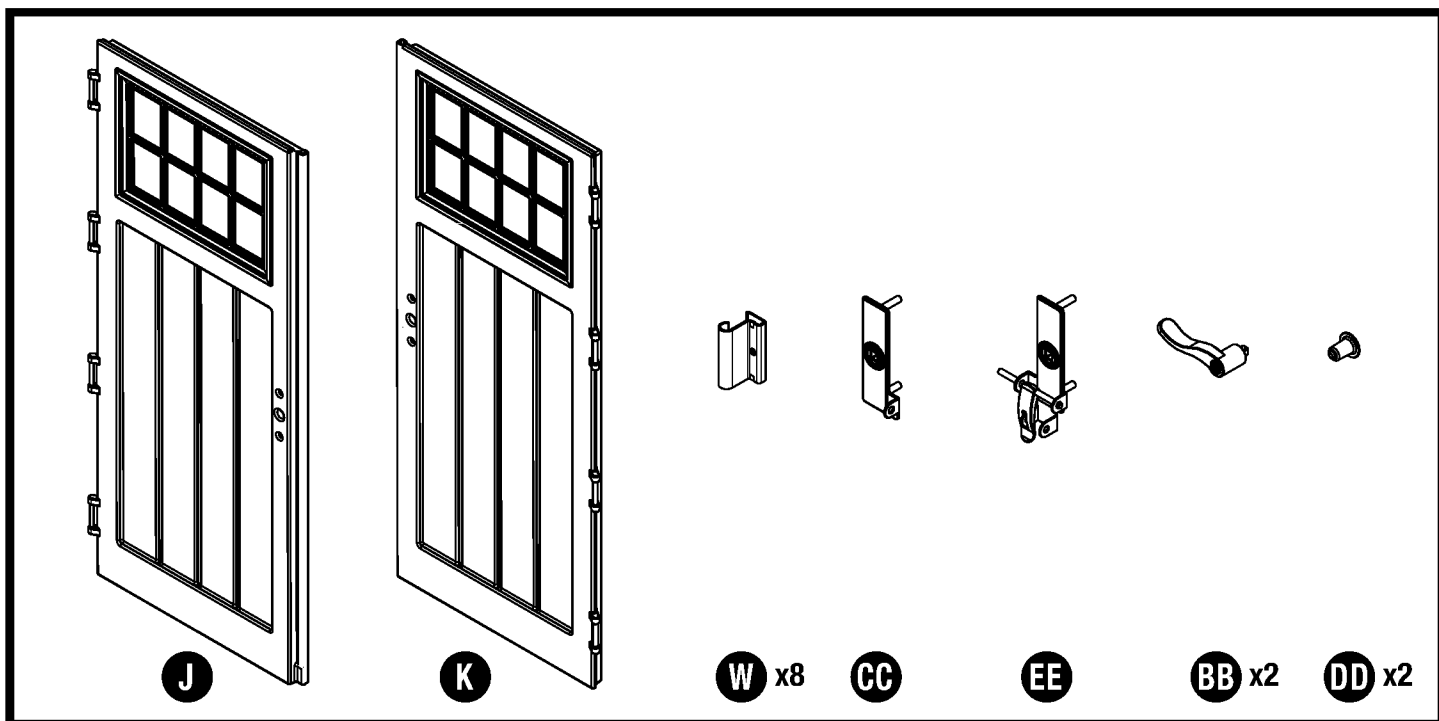
Shed Assembly/Doors



 **Note:** At least two people are needed during assembly.

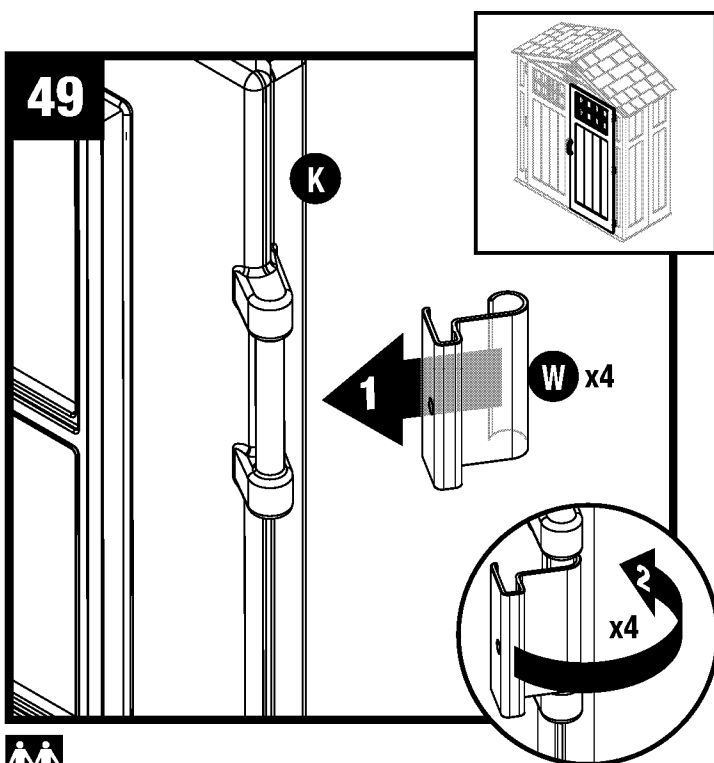

 Stand right door (K) upright with four hinge mounts facing right. Attach one metal hinge plate (W) to each hinge mount. Rotate hinge plates to inside of door.

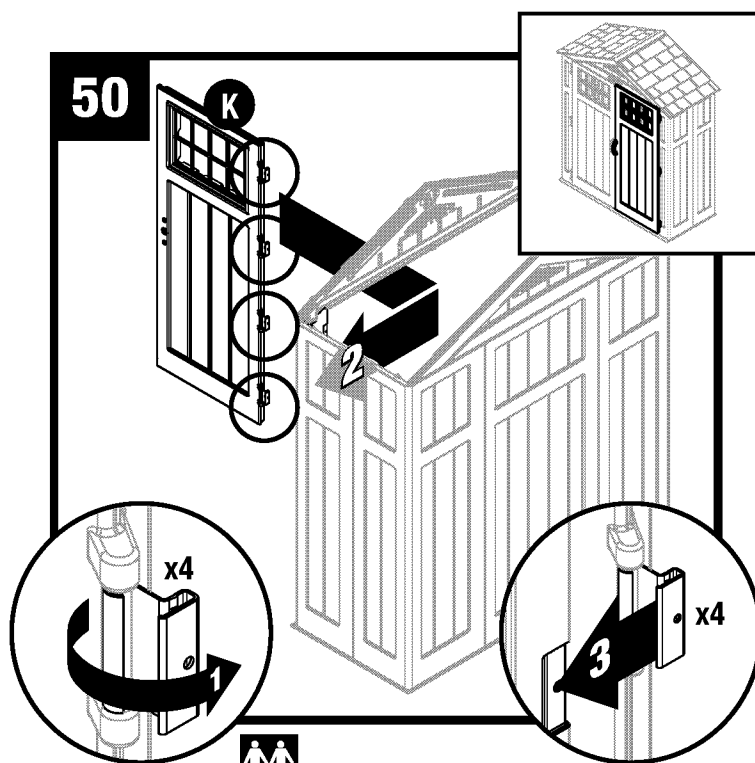

 Rotate metal hinge plates to open position. Slide one metal hinge plate over each hinge receptacle on inside of right front panel.

Note: For clarity, illustration is shown with roof removed.

Shed Assembly/Doors (continued)

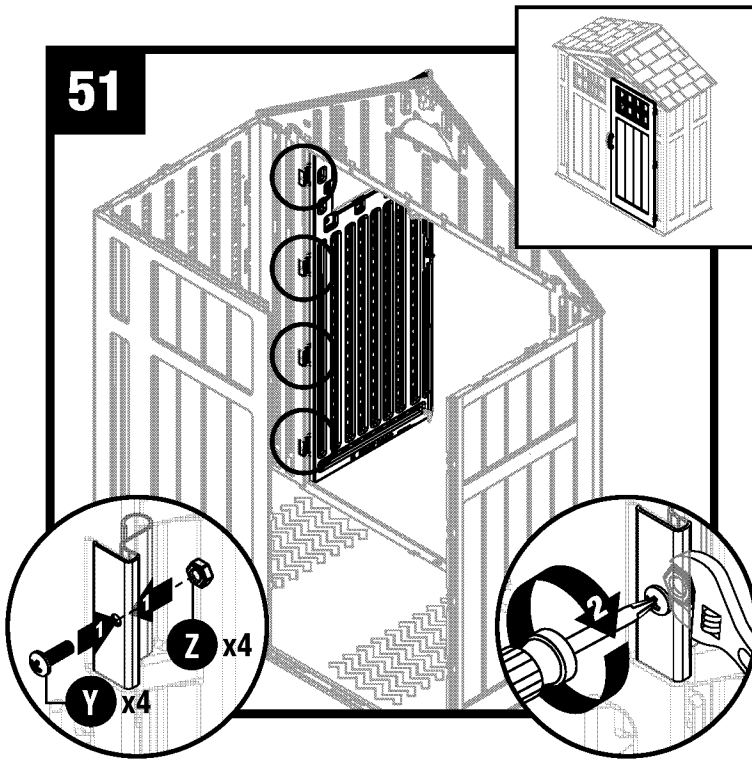

Secure each metal hinge plate with one screw (Y) and one nut (Z).

Repeat Steps 47-49 for left door (J).

Note: For clarity, illustration is shown with roof, rear header, and back panel removed.

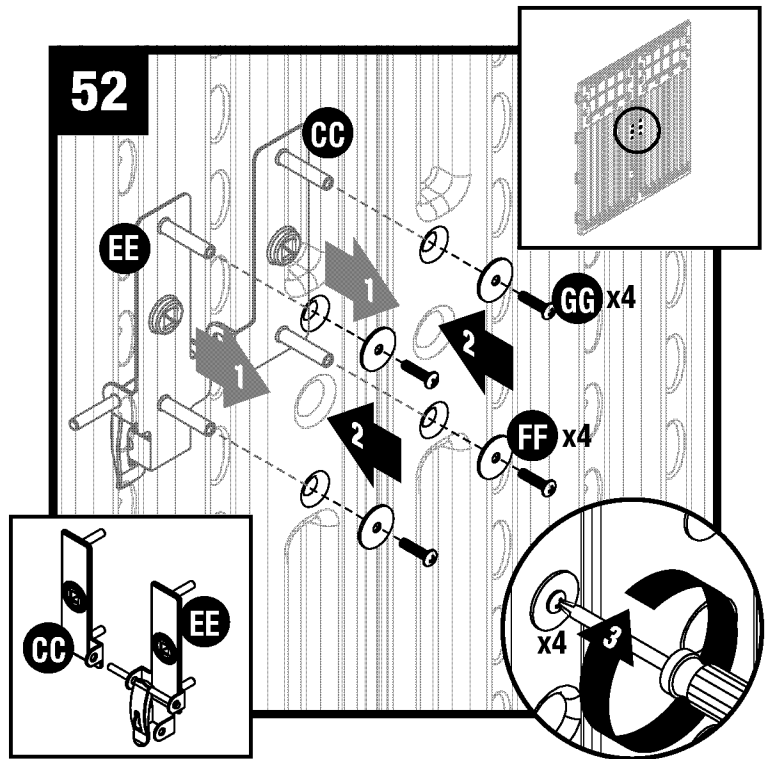

Insert screw stems, on left and right handle plates (CC) and (EE), through the pre-drilled holes in doors. While holding plates in place on exterior of door, secure each with two washers (FF) and two screws (GG).

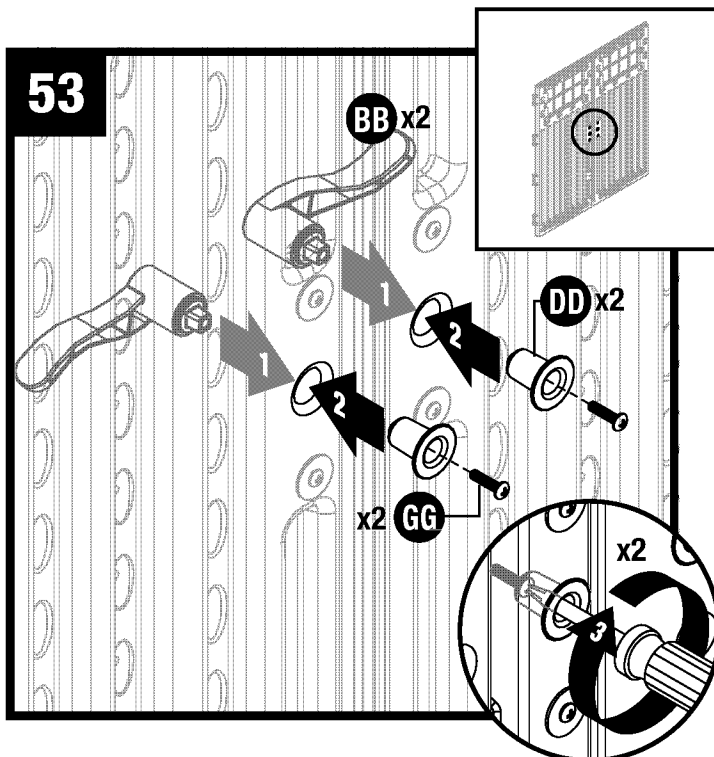

From the outside of doors, insert door handles (BB) through handle plate holes. On inside of doors, place spacers (DD) on each door handle, and secure each with one screw (GG).



Complete.

Warranty

Suncast® Corporation, 701 North Kirk Road, Batavia, Illinois 60510 (Manufacturer) warrants to the original purchaser only that the enclosed product is free from material and workmanship defects under normal, household use at time of purchase.

This limited warranty does not apply to damage resulting from accident, neglect, misuse, commercial use, alteration, operation not in accordance with instruction or repairs made or attempted by unauthorized persons.

This limited warranty applies only to the product enclosed and does not apply to accessory parts.

THE MANUFACTURER'S LIABILITY HEREUNDER IS LIMITED SOLELY TO THE REPAIR OR REPLACEMENT OF THE DEFECTIVE PRODUCT OR PART AND THE MANUFACTURER SHALL IN NO EVENT BE LIABLE FOR ANY INCIDENTAL OR CONSEQUENTIAL DAMAGES WHICH MAY RESULT FROM ANY DEFECT IN MATERIAL OR WORKMANSHIP OR FROM THE BREACH OF ANY EXPRESS OR IMPLIED WARRANTY.

Some states do not allow the exclusion or limitation of incidental or consequential damages, or a limitation of how long an implied warranty lasts, so the above limitations may not apply to you. This warranty gives you specific legal rights, and you may have other rights which may vary from state to state.

Quality Control Number

